

# GlasRoc<sup>®</sup> Shaftliner and M2Tech<sup>®</sup> Shaftliner

For Area Separation Firewalls

# The GlasRoc® and M2Tech® Shaftliner advantage

GlasRoc® and M2Tech® Shaftliner are specially formulated Type X products for applications where enhanced mold resistance is preferred. They can be used for firewalls in standard multi-family residential applications.

## GlasRoc® SHAFTLINER

GlasRoc® Shaftliner is a paperless mold and moisture resistant gypsum panel combining reinforcing glass mats and a specially formulated fire and moisture resistive, non-combustible core. GlasRoc® Shaftliner provides:

- Long term protection (12 months) to weather exposure.
- A superior water resistant surface that does not inhibit water vapor permeance.
- Excellent Type X fire resistance properties, and numerous fire rated designs.
- Achieves score of 10 for mold resistance per ASTM D3273.

## M2TECH®

M2Tech® gypsum panel features M2Tech® moisture and mold resistant technology. M2Tech® gypsum panels provide:

- Additional zone of protection against moisture and mold
- Numerous Type X fire-rated assembly designs for safety and performance
- Easy to cut and install. Does not require special tools
- May be finished, painted, or wallpapered using conventional gypsum panel techniques
- Achieves score of 10 for mold resistance per ASTM D3273

GlasRoc® and M2Tech® Shaftliner, and CertainTeed's gypsum panels that include M2Tech® technology, can be combined to offer superior mold resistance performance for Area Separation Firewalls.

Gypsum Area Separation Firewall systems are IBC and NBCC code approved (up to STC 71) and replace traditional masonry for fire separation between multi-family units. Some inherent advantages of gypsum Area Separation Firewalls are: lighter weight, reduced thickness, ease and speed of

installation, no requirement for scaffolding, and no requirement for an additional trade on the job.

Area Separation Firewalls offer the advantages of fire resistance and noise attenuation between adjoining housing units. These walls offer a 2-hour fire resistance rating line of defense between units and provide sound ratings up to STC 71 when 1/2" (12.7 mm) SilentFX® Quickcut™ is used as a substitute.

### GLASROC® SHAFTLINER

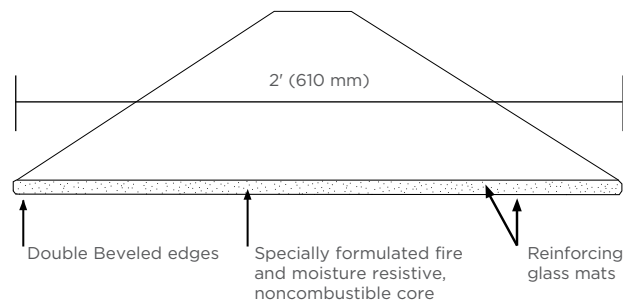

### M2TECH® SHAFTLINER

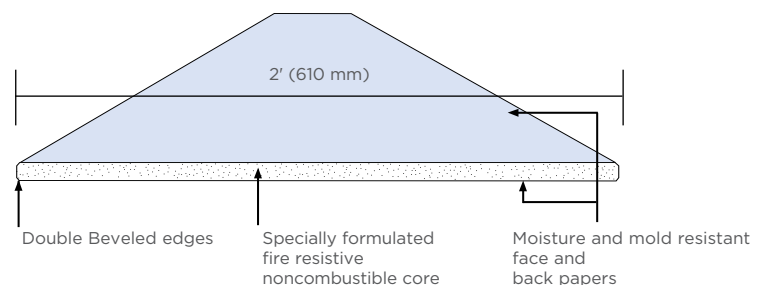

GlasRoc® and M2Tech® Shaftliner are designed and engineered for use in construction of lightweight Shaftwall and Area Separation Firewalls. These systems are UL, cUL, and ULC listed for fire resistance. GlasRoc® and M2Tech® Shaftliner can be substituted with each other.

GlasRoc® and M2Tech® Shaftliner are 1" (25.4 mm) thick gypsum panels with a specially formulated, Type X, fire resistive, noncombustible core. Double beveled edges make installation easier.

M2Tech® Shaftliner is enclosed in a moisture and mold resistant, blue-gray tinted, 100% recycled paper.

GlasRoc® Shaftliner has reinforced glass mats. When tested for mold resistance by an independent lab at the time of manufacturing, GlasRoc® and M2Tech® Shaftliner achieved the highest possible score of 10 per ASTM D3273, "Standard Test Method for Resistance to Growth of Mold on the Surface of Interior Coatings in an Environmental Chamber".

# Area Separation Firewalls

**GlasRoc® and M2Tech® Shaftliner are used in conjunction with other CertainTeed gypsum panel products in Area Separation Firewalls.**

Area Separation Firewalls are solid type separation walls assembled using 1" (25.4 mm) M2Tech® Shaftliner gypsum panels, metal framing and 1/2" (12.7 mm) CertainTeed Easi-Lite®, M2Tech® or SilentFX® QuickCut™ gypsum panels for the interior finish. The firewall is easily stacked, floor to floor, allowing progressive construction.

For projects that require an exposure warranty for the shaftliner panel due to

prolonged exposure to the elements or inclement weather, we recommend GlasRoc® Shaftliner with its 12 month exposure Limited Warranty.

Breakaway aluminum clips are used to attach the interior wall to adjacent structural metal framing and provide lateral support. When one side is exposed to fire, the clips yield to the heat and break away allowing the gypsum panel interior wall on the fire side to collapse. Thus the Area

Separation Firewall remains intact to protect neighboring spaces.

Area Separation Firewalls are easier and faster to construct, lighter weight, and take up less space than masonry wall systems.

- Thickness:** 1" (25.4 mm)
- Widths:** 2' (610 mm) Standard
- Lengths:** 8' (2440 mm), 10' (3050 mm) and 12' (3660 mm) Standard
- Edges:** Double beveled

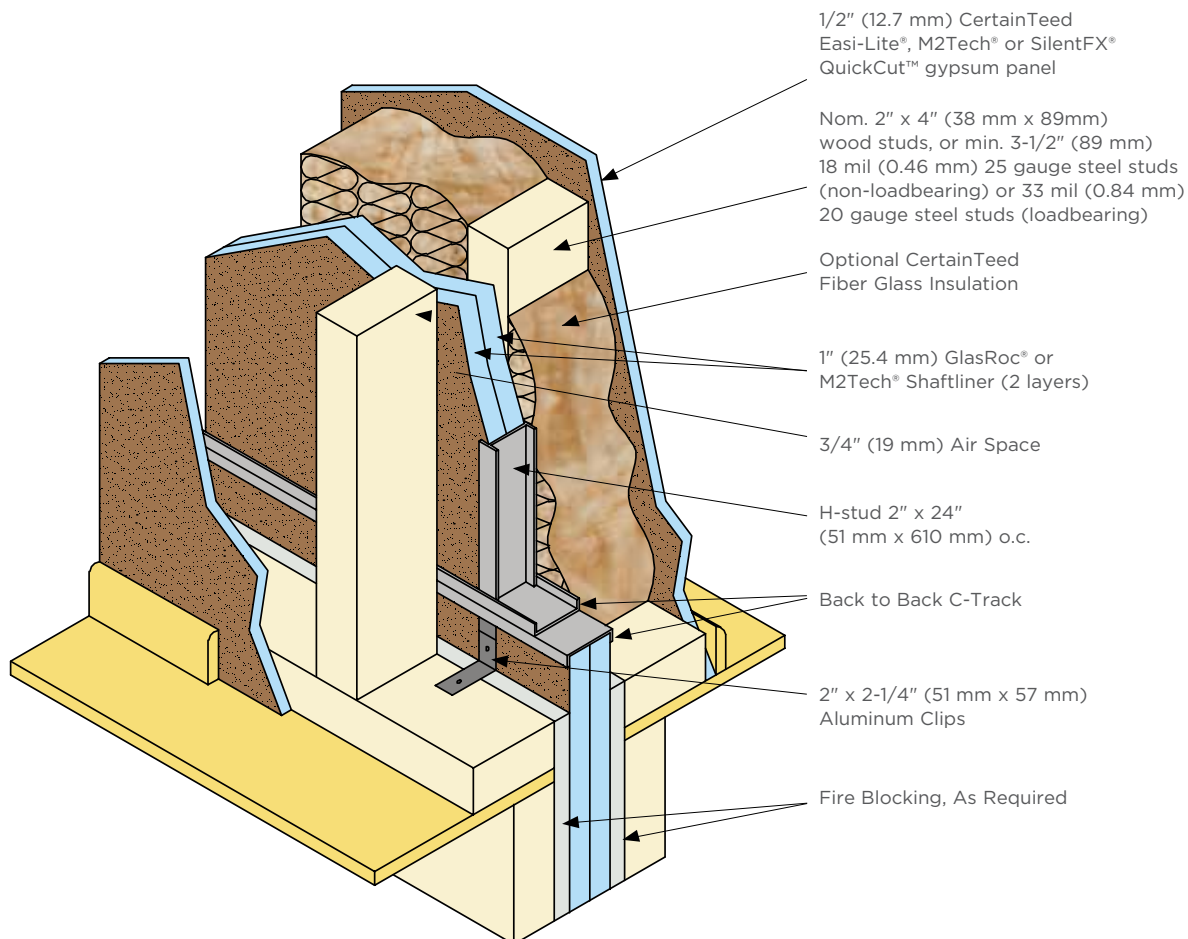





# Working with the Products

## HANDLING AND STORAGE

CertainTeed gypsum panels should be stacked flat on a smooth, level surface, not stored directly on the ground. When spacers are used, position them closely enough together to minimize warpage. Care should be taken to prevent damage to edges and corners. Always keep gypsum panels dry prior to installation.

CertainTeed assumes no responsibility for consequential damages that may result from the presence of standing water or where moisture is in direct contact with Area Separation Firewall system components.

## CUTTING

The score and snap method is a fast and efficient way to cut gypsum panels.

### Steps:

1. On the face (logo) side, position a straight edge along the line of cut.
2. Score sheets with a knife or other suitable tool.
3. With a quick, firm motion, snap back away from the face.
4. The back paper/glass can be cut with either a knife or suitable tool, then separated by snapping the piece in the opposite direction.
5. Smooth all cut ends and edges to ensure tight joints.

To make cut outs, score around the perimeter on the face and back and tap out the waste piece from the face side. Cut outs can also be made with a drywall saw. Safety glasses should always be worn when using power tools. For information on avoiding dust inhalation, refer to the Safety Data Sheet available on our web site, [www.certainteed.com](http://www.certainteed.com).

## INSTALLATION

Steel framing and installation of 1" (25.4 mm) GlasRoc® or M2Tech® Shaftliner gypsum panel for solid type Area Separation Firewalls are used as the common wall of one unit. An Area Separation Firewall can be constructed by following these steps before continuing to frame the adjacent unit.

### 2 Hour Area Separation Firewall (UL U366, ULC W311) (Non-Loadbearing):

1. Attach 2" (51 mm) wide C-Track to slab at bottom of wall using suitable fasteners at a maximum of 24" (610 mm) o.c. Allow a 3/4" (19 mm) space from wood or steel stud framing on each side of the firewall.
2. Install vertical C-Track at the beginning of the wall and support as needed.
3. Insert two sections of 1" (25.4 mm) GlasRoc® or M2Tech® Shaftliner gypsum panel in bottom channel with logo side facing weather exposure during construction. Plumb panels to vertical C-Track.
4. Install 1" (25.4 mm) GlasRoc® or M2Tech® Shaftliner gypsum panels vertically. Continue wall as needed by placing H-Studs between the proceeding panels every 24" (610 mm) for the length of the wall and enclose the end panels with vertical C-Track.
5. Cap the wall assembly before continuing higher using C-Track fastened to the H-Studs on alternate sides with 3/8" (10 mm) Type S screws. A second C-Track for the next row of shaftliner panels is then placed back to back with end joints staggered at least 12" (300 mm) o.c. and fastened with double 3/8" (10 mm) Type S screws at ends and 24" (610 mm) o.c.
6. Attachment Clips: Aluminum angle, 0.063" (1.6 mm) thick, min. 2" (51 mm) wide with min. 2" (51 mm) and 2-1/4" (57 mm) legs. Clips secured to each side of every H-Stud (two per stud) with Type S screws 3/8" (10 mm) long to H-Studs and steel framing, and with Type W screws 1-1/4" (32 mm) long to wood framing through holes provided in the clip. Clips spaced a max of 10' (3 m) o.c. vertically between wood or steel framing and H-Studs for separation firewalls up to 23' (7 m) high. For separation firewalls up to 70' (21.3 m) high, clips spaced as described above for the upper 24' (7.3 m) and the remaining wall area below requires clips spaced a max. 5' (1.5 m) o.c. vertically between wood framing and H-Studs.

7. This assembly can be repeated, per plan, up to 70' (21.3 m) high. Cap the top of the assembly with 2" (51 mm) C-Track and protect the entire installation from moisture.
8. Where required, use an approved acoustical sealant, such as SilentFX® Noiseproofing Sealant to caulk around the perimeter of wall sections and between horizontal back-to-back C-tracks.

### 3 Hour Area Separation Firewall (UL/cUL W467)

1. Attach 2" (51 mm) wide C-Track to slab at bottom of wall using suitable fasteners at a maximum of 24" (610 mm) o.c.
2. Install vertical C-Track at the beginning of the wall and support as needed.
3. Insert two sections of 1" (25.4 mm) GlasRoc® or M2Tech® Shaftliner gypsum panel in bottom channel with logo side facing weather exposure during construction. Plumb panels to vertical C-Track.
4. Install 1" (25.4 mm) GlasRoc® or M2Tech® Shaftliner gypsum panels vertically. Continue wall as needed by placing H-Studs between the proceeding panels every 24" (610 mm) for the length of the wall and enclose the end panels with vertical C-Track.
5. Cap the wall assembly before continuing higher using C-Track fastened to the H-Studs on alternate sides with 3/8" (10 mm) Type S screws. A second C-Track for the next row of shaftliner panels is then placed back to back with end joints staggered at least 12" (300 mm) o.c. and fastened with double 3/8" (10 mm) Type S screws at ends and 24" (610 mm) o.c.
6. Apply 5/8" CertainTeed Type C Gypsum Panel, horizontally or vertically, to H-Studs with 1" (25.4 mm) long Type S screws 16" (406 mm) o.c. Vertical joints centered over the H-Studs.
7. Attachment Clips: Aluminum angle, 0.049" (1.25 mm) thick, min. 2" (51 mm) wide with min. 2" (51 mm) and 2-1/2" (64 mm) legs. Clips secured to each side of every H-Stud (two per stud) with Type S screws 1" (25.4 mm) long to H-Studs and steel framing, and with 1-1/4" (32 mm) long Type W screws



to wood framing through holes provided in the clip. Clips spaced a maximum of 5' (1.5 m) o.c. vertically between wood or steel framing and H-Studs.

8. This assembly can be repeated, per plan, up to 70' (21.3 m) high. Cap the top of the assembly with 2" (51 mm) C-Track and protect the entire installation from moisture.
9. Where required, use an approved acoustical sealant, such as SilentFX® Noiseproofing Sealant to caulk around the perimeter of wall sections and between horizontal back-to-back C-tracks.

## INTERIOR FINISH WALLS

### 2 or 3 hour assembly (UL U366, ULC, W311, UL/cUL W467)

1. **Wood Studs** - 2" x 4" nom. (38 mm by 89 mm) max. spaced 24" (610 mm) o.c.  
**Steel Studs** - Min. 3-1/2" (89 mm) 0.46 mm (18 mils) for non-loadbearing or 33 mil (0.84 mm) 20 gauge for loadbearing walls max. spaced 24" (610 mm) o.c. Studs cross-braced at mid-height where necessary for clip attachment. **2 Hour Assembly:** Min. 3/4" (19 mm) separation between wood or steel framing and Area Separation Firewall. As an alternate to the 3/4" (19 mm) separation air space from wood or steel framing, the center Area Separation Firewall steel framing components are permitted to be covered with 6" (150 mm) wide batten strips of 1/2" (12.7 mm) CertainTeed® Type C Gypsum Panel attached to the steel framing with 1" (25.4 mm) Type S drywall screws spaced 12" (300 mm) o.c. Accessible attic areas typically use this alternate method. Non-accessible attic areas do not require the 6" (150 mm) wide gypsum panel batten strips.  
**3 Hour Assembly:** 3/4" air space not required between framing and fire separation wall.
2. Insulation (Optional) - CertainTeed Fiber Glass Insulation, or equivalent, installed between wood or steel studs to meet listed STC performance.
3. CertainTeed gypsum panel, min. 1/2" (12.7 mm) thick, 4' (1220 mm) wide, applied either horizontally or vertically. Gypsum panel attached to wood studs with 1-1/4"

(32 mm) long drywall nails or 1-1/4" (32 mm) Type W drywall screws spaced 8" (200 mm) o.c. Gypsum panel attached to steel studs with min. 1" (25.4 mm) Type S drywall screws spaced 12" (300 mm) o.c. Vertical joints located over studs. Joints and fasteners finished with CertainTeed Finishing system or equivalent.

### Surface Preparation of Finished Sides

Joints, corners and fastener heads on the face side shall be finished in accordance with ASTM C840, GA-214, GA-216, GA-600 Fire Resistance and Sound Control Design Manual and joint compound manufacturer's instructions. Joint compound shall comply with ASTM C475.

1. No surface treatment shall be done until the interior temperature has been maintained at a minimum of 50°F (10°C) for at least 48 hours prior to application of compounds and until all materials have completely dried. Adequate continuous ventilation must also be provided.
2. Fill and level joints with CertainTeed joint compound.
3. Embed tape into the wet compound and allow to dry. For inside corners, crease the tape and work it into joint.
4. Apply a second coat of compound across the joint and feather to approximately 4" (100 mm) on each side.
5. Apply a third coat and feather to approximately 6" (150 mm) on each side.
6. Allow each coat to dry before proceeding. Refer to GA-236 for the effects of environmental conditions on drying times.
7. Attach corner bead to outside corners and apply three coats of joint compound. Feather out each coat as described in steps 4-6.
8. Spot cover all fastener heads with three coats of joint compound applied in different directions.
9. Lightly sand the last coat of all treated areas, taking care not to rough the surrounding gypsum panel paper. Smoothing can also be accomplished with a damp sponge.

### Finishing Interior Walls

CertainTeed gypsum panels can be finished with paint, texture or wallpaper. High quality primer/sealer must be used prior to any type of final decoration. For high gloss paint and severe lighting conditions, a thin skim coat of joint compound or CertainTeed Level V Wall/Ceiling Primer Surfacer should be applied across the entire surface (Level 5 Finish). This will help minimize the irregularities and porosity differences between the materials. Refer to GA-214, GA-216, and ASTM C840 for additional finishing instructions. Finishing is not required on the Area Separation Firewall.

## LIMITATIONS

- This Area Separation Firewall is a non-loadbearing partition.
- CertainTeed gypsum panels must not be used in areas that are continuously or repeatedly exposed to excessive moisture or dampness.
- Systems shall not be exposed to sustained temperatures exceeding 125°F (52°C).
- Do not use shaftliner panels in unlined air-supply ducts.
- CertainTeed gypsum panels should not come in direct contact with concrete, masonry or other surfaces that have a high moisture content.
- Unsupported wall height between floors should not exceed 12' (3660 mm). The assembly may be used in buildings up to 4 stories with a total height not to exceed 70' (21.3 m).
- Penetrations through the solid 2" (51 mm) Firewall should be protected by a Firestop System in accordance with IBC, Chapter 7 and NBCC Part 3.1.9 or NBCC in Canada.
- Penetrations in the solid 2" (51 mm) Area Separation Firewalls designed as a Party Wall (a wall located on a property line between adjacent buildings which is used or adapted for joint service between the two buildings), i.e. town-homes, are usually not permitted by code authorities. Consult your local building code authority.

# GlasRoc® and M2Tech® Shaftliner for Area Separation Firewalls

## Non-loadbearing

### FIRE RATING - 2 HOUR

#### EXPOSED TO FIRE FROM AREA SEPARATION FIREWALL EITHER SIDE

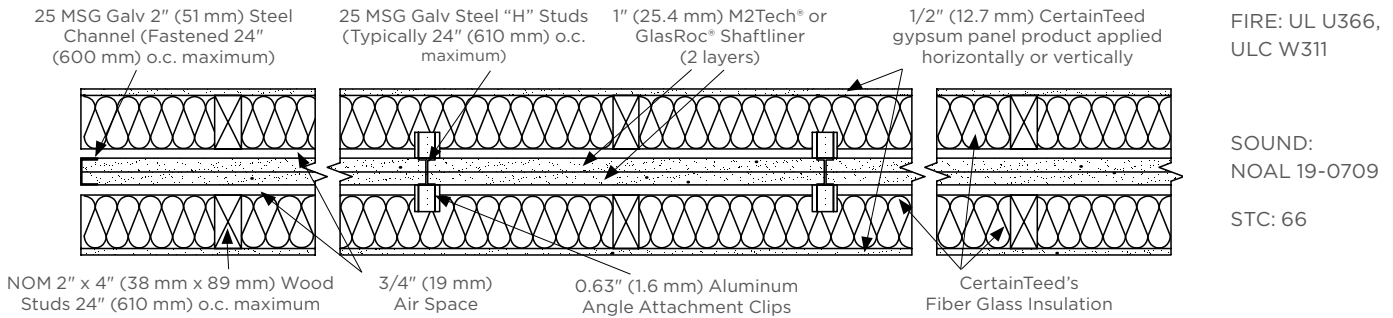

#### EXPOSED TO FIRE FROM EITHER SIDE

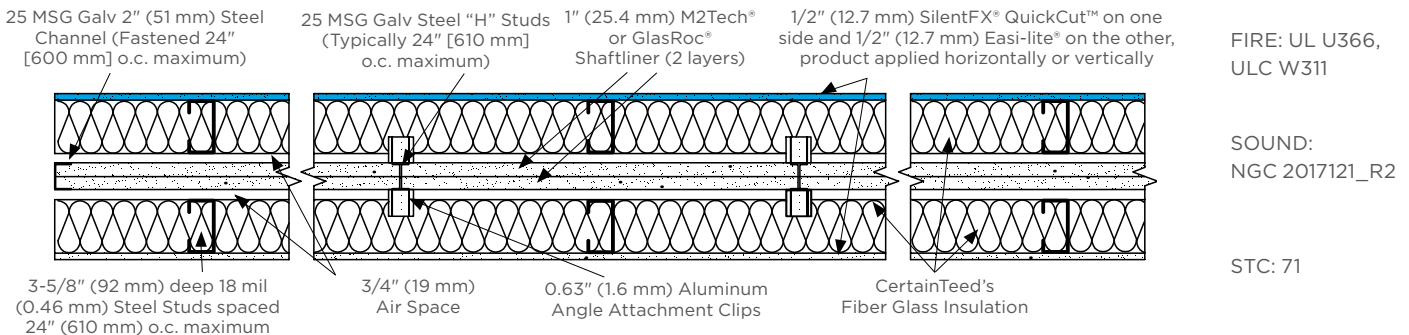

### FIRE RATING - 3 HOUR

#### EXPOSED TO FIRE FROM AREA SEPARATION FIREWALL EITHER SIDE

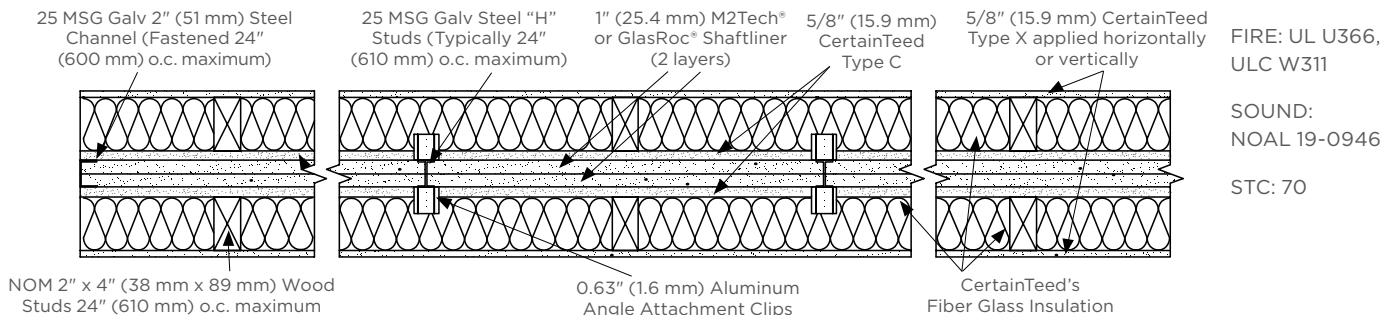

# GlasRoc® and M2Tech® Shaftliner for Area Separation Firewalls

## TYPICAL INSTALLATION DETAILS

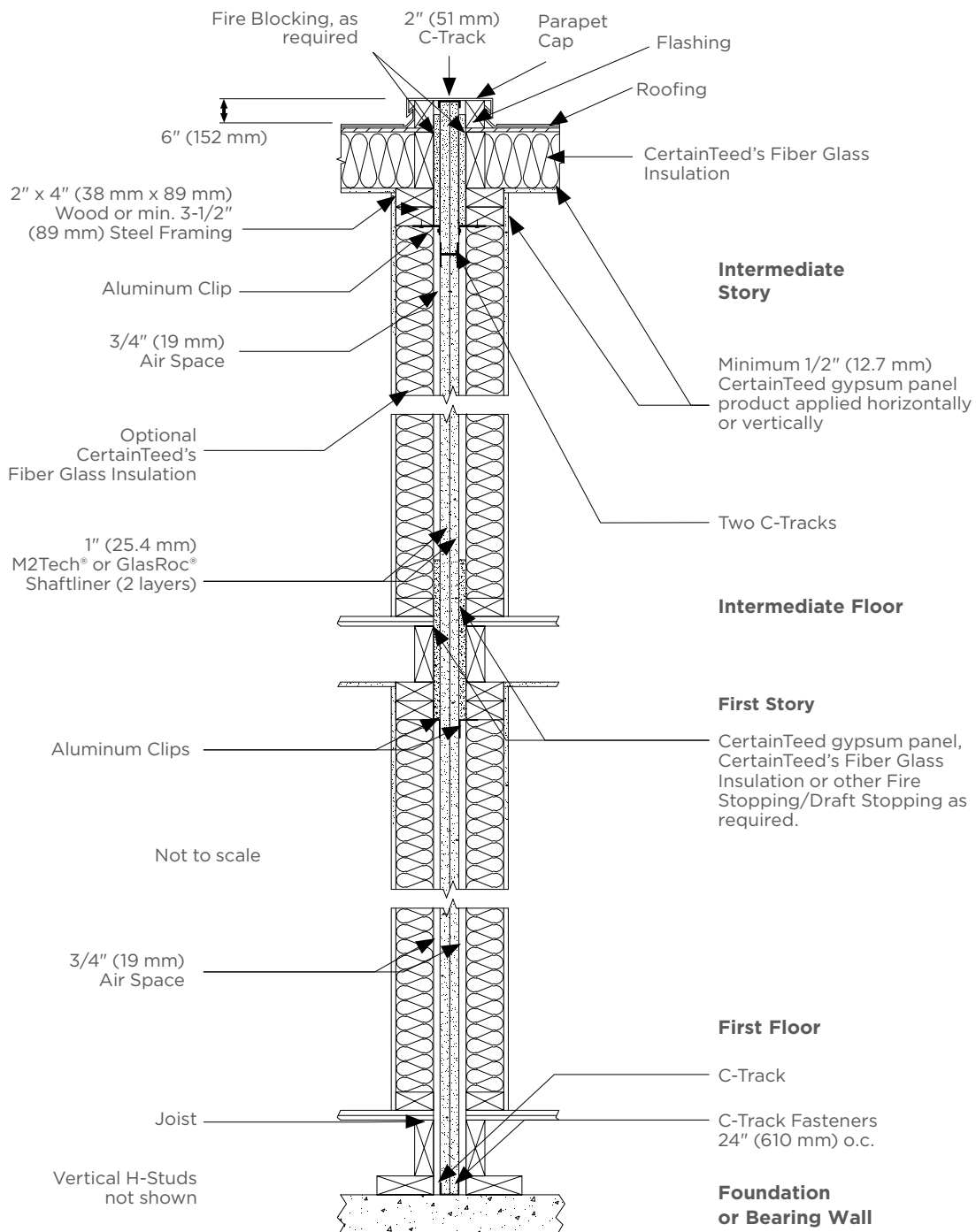

# GlasRoc® and M2Tech® Shaftliner for Area Separation Firewalls

## INTERMEDIATE FLOOR INTERSECTION LOCATION OF ASW CLIPS

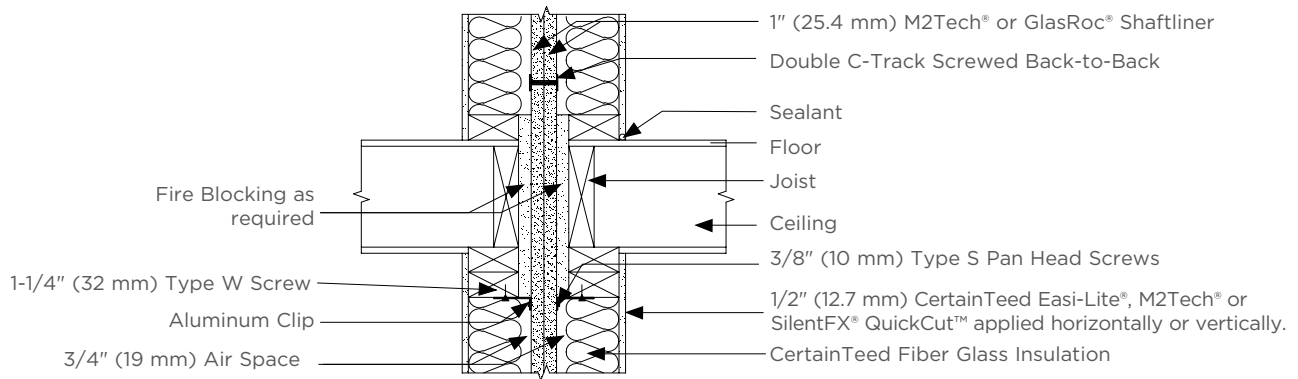

## EXTERIOR WALL INTERSECTION

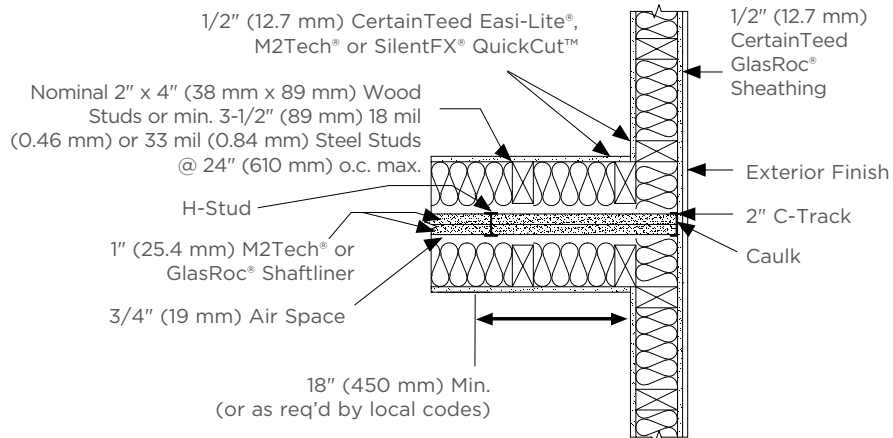

## PROTRUDING EXTERIOR WALL

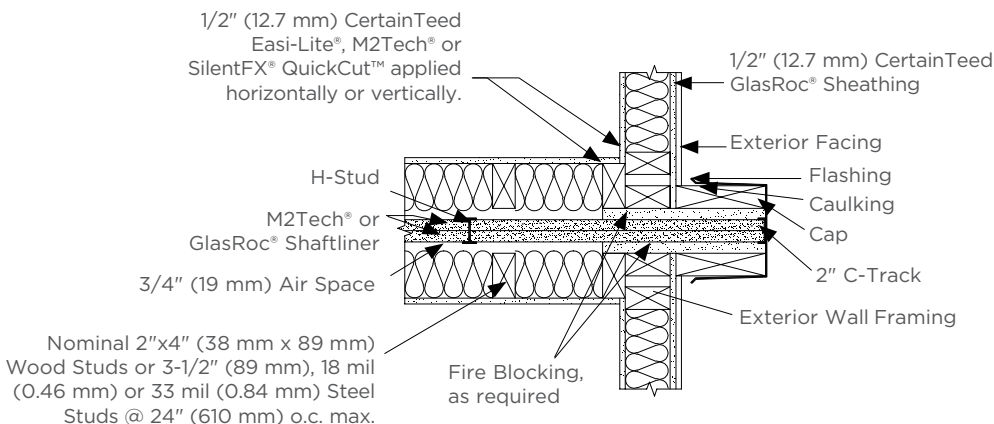



# GlasRoc® and M2Tech® Shaftliner for Area Separation Firewalls

## TYPICAL ROOF PARAPET DETAIL

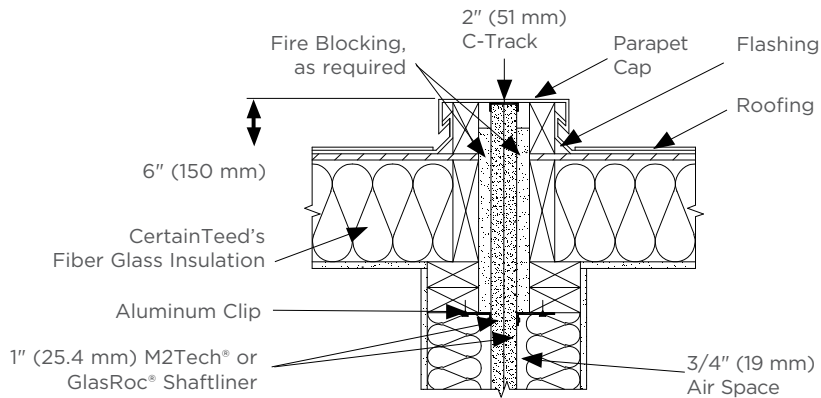

## TYPICAL ROOF JUNCTION DETAIL

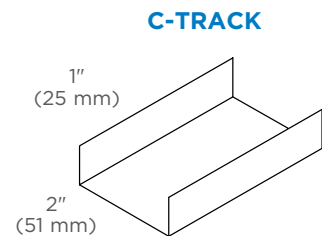
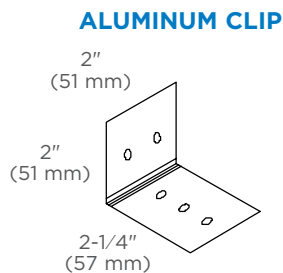
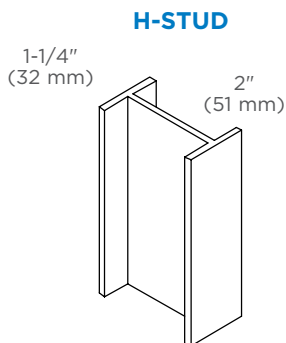
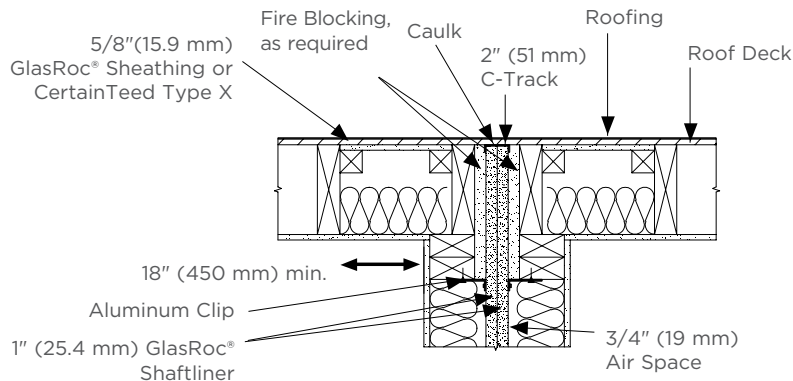

# GlasRoc® and M2Tech® Shaftliner for Area Separation Firewalls

## COMPONENT SPECIFICATIONS

	M2Tech® Shaftliner	GlasRoc® Shaftliner	Steel
Standard	ASTM C1396	ASTM C1658, C1396	C-Track 18 mil (0.46 mm) 2" (51 mm)
Thickness	1" (25.4 mm)	1" (25.4 mm)	H-Stud 18 mil (0.46 mm) 2" (51 mm)
Width	2' (610 mm)	2' (610 mm)	Aluminum Clip 0.63" (1.6 mm), 2" (51 mm)
Lengths	8' (2440 mm) 10' (3050 mm) 12' (3660 mm)	8' (2440 mm) 10' (3050 mm) 12' (3660 mm)	
Approx. Weight	4.0 psf (19.5 kg/m <sup>2</sup> )	4.0 psf (19.5 kg/m <sup>2</sup> )	
Edges	Double Beveled	Double Beveled	

Consult local building codes for regulations in your area.

## SURFACE BURNING CHARACTERISTICS

M2Tech® Shaftliner		
Standard	Flame Spread	Smoke Developed
ASTM E84	15	0
CAN/ULC-S102	0	0

GlasRoc® Shaftliner		
Standard	Flame Spread	Smoke Developed
ASTM E84	0	0
CAN/ULC-S102	0	0

## TECHNICAL REFERENCES

- ICC International Codes
- UL U366, ULC W311
- UL/ULC Type Designation: Shaftliner, GlasRoc Shaftliner, LGFCSL
- Gypsum Association Publications GA-214, GA-216, GA-620 and GA-600
- ASTM E84 (CAN/ULC-S102), ASTM E119 (CAN/ULC-S101), ASTM E90
- NGC Testing Services NGC 2017121\_R2
- North Orbit Acoustic Laboratory Facility: NOAL 19-0709 and NOAL 19-0946
- ICC ESR-1338
- International Building Code and National Building Code of Canada

## BUILDING RESPONSIBLY

Through the responsible development of innovative and sustainable building products, CertainTeed has helped shape the building products industry for more than 100 years. Founded in 1904 as General Roofing Manufacturing Company, the firm's slogan "Quality Made Certain, Satisfaction Guaranteed," quickly inspired the name CertainTeed. Today, CertainTeed is North America's leading brand of exterior and interior building products, including roofing, siding, fence, decking, railing, trim, gypsum, ceilings and insulation.



USGBC® and the related logo are trademarks owned by the U.S. Green Building Council® and are used with permission.

The Health Product Declaration® logo is a trademark or service mark of Health Product Declaration Collaborative, Inc., in the United States and in other countries and is being used herein under license.



- Resists mold growth per ASTM D3273
- Added protection from incidental moisture during construction
- UL Classified and ULC Listed for Fire Resistance and Surface Burning Characteristics
- Rapid ease of installation reduces overall construction time and provides a cost-effective system
- Area Separation Firewall ratings up to two hours with high STC
- 12 month limited warranty against weather exposure for GlasRoc<sup>®</sup> Shaftliner
- BIM/CAD Information UL fire rated assemblies and sound assemblies can be found on CertainTeed's BIM and CAD Design studio at [bimlibrary.saint-gobain.com](http://bimlibrary.saint-gobain.com).
- Sustainable documentation, including recycled content, EPD's, HPD's, and VOC Certifications, can be found at [saintgobain.ecomedes.com](http://saintgobain.ecomedes.com).

learn more at:  
[certainteed.com/drywall](http://certainteed.com/drywall)

USGBC<sup>®</sup> and the related logo are trademarks owned by the U.S. Green Building Council<sup>®</sup> and are used with permission.



The Health Product Declaration<sup>®</sup> logo is a trademark or service mark of Health Product Declaration Collaborative, Inc., in the United States and in other countries and is being used herein under license.

