

Aluminum handrail component system

- ◆ Complies with ADA (Americans with Disabilities Act) requirements for grippable handrails
- ◆ Aluminum construction reduces bowing and provides enduring strength
- ◆ 1-1/2" diameter gripping area
- ◆ Continuous handrail runs
- ◆ Safe for stair and ramp applications
- ◆ Functional finishing touches: post and wall returns, end caps, return loops and a convenient straight joiner
- ◆ Unique adjustable joiners accommodates any transition – 0° to 90° bends
- ◆ Installs easily on site with no preformed fittings
- ◆ Ideal for use with EverNew railing systems
- ◆ Virtually maintenance free
- ◆ Lifetime limited warranty
- ◆ EZ Set bracket kit available for attachment to routed system

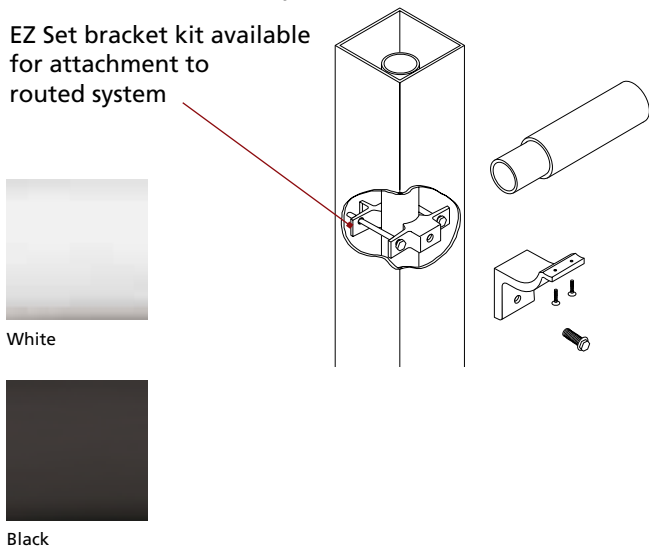

Note: Handrail depicted is not free standing and must be anchored to walls or guardrail using handrail bracket assembly (74028/74029). Space a maximum of 6' on center and as close as possible to both sides of any joint. (ADA compliant at 6ft spans)

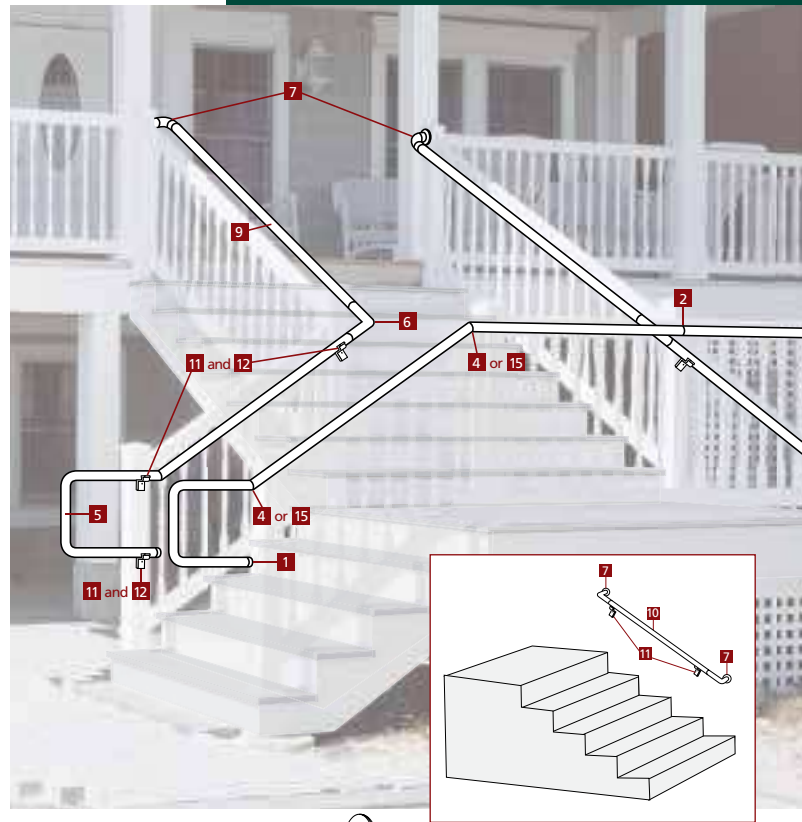

- 1 1-1/2" diameter end cap
- 2 Straight aluminum joiner
- 3 Straight wall return
- 4 Adjustable aluminum internal joiner
- 5 1-1/2" OD ADA 180° return loop
- 6 1-1/2" OD - 90° corner - includes two 3" aluminum joiners
- 7 1-1/2" OD - 90° wall return - includes 3" aluminum joiner
- 8 1-1/2" OD x 80" handrail
- 9 1-1/2" OD x 104" handrail
- 10 1-1/2" OD x 120" handrail
- 11 Handrail bracket assembly
- 12 Handrail EZ Post attachment kit
- 13 Handrail joint ring
- 14 Inside corner bracket
- 15 Adjustable aluminum external joiner