

**MANUAL**

**FOR**

**CERTAINTEED MACHINE WORKS**

**ELECTRIC Volu-Matic™ SE**

**INSULATION BLOWING MACHINE**

**PLEASE READ THIS MANUAL THOROUGHLY BEFORE PUTTING THE  
ELECTRIC VOLU-MATIC™ SE INSULATION BLOWING MACHINE INTO SERVICE!**

MANUFACTURED BY:  
CertainTeed Machine Works  
101 Hatfield Rd.  
Winter Haven, Florida 33880  
1-800-237-7841  
[www.certainteedmachineworks.com](http://www.certainteedmachineworks.com)

## TABLE OF CONTENTS

SPECIFICATIONS _____	1
INTRODUCTION _____	2
SAFETY _____	4
INSTALLATION _____	8
OPERATION _____	9
PREVENTIVE MAINTENANCE _____	18
TROUBLESHOOTING _____	22
PARTS DRAWINGS _____	26
WARRANTY	

**Check the accessory kit included with new delivered machines that the following items were received for operation.**

<u>Quantity</u>	<u>Item Description</u>
1	150 foot long remote control cord
1	Stator bar
1	Complete set of spare fuses
2	#40 and #50 chain connector links
2	#40 and #50 chain connector half links
6	Shear keys
1	1/8" and 5/32" Allen wrench

# ELECTRIC *Volu-Matic*™ SE INSULATION BLOWING MACHINE

## SPECIFICATIONS

### MODEL:

**VM-SE4E2:** 7.5 horse power blower motor, 5 horse power mechanism motor, 24 volt remote control, 18 inch airlock feeder, air volume control system, positive displacement blower, four speed transmission.

HEIGHT: 69.00 INCHES

LOAD HEIGHT: 59.00 INCHES

LENGTH: 72.00 INCHES

WIDTH: 48.25 INCHES

WEIGHT: 1300 POUNDS

ELECTRICAL: Three phase, 60 Hertz, 208-230/460 volts, 50/30 amp service  
Three phase, 50 Hertz, 220/380/440 volts, 60/35/30 amp service

BLOWER VOLUME: 270 CFM @ 2 PSI

HOSE REQUIREMENT: 3 ½" I.D. minimum x 150' length minimum – open blow  
3" I.D. or 2 ½" I.D. minimum x 150' length minimum – sidewall

HOSE MANUFACTURER: Flexaust Mark II

### MAXIMUM FEED RATE:

CELLULOSE: 70 - 80 pounds per minute @ 2.0 PSI.

FIBERGLASS: 25 - 35 pounds per minute @ 3.5 PSI.

ROCKWOOL: 35 - 55 pounds per minute @ 4.5 PSI.

**WARNING: RECOMMENDED HOSE SIZE, TYPE, AND LENGTH MUST BE USED TO ACHIEVE MAXIMUM RESULTS. CERTAINTIED MACHINE WORKS CANNOT GUARANTEE PERFORMANCE OF THE *ELECTRIC VOLU-MATIC*™ SE MACHINE IF HOSES ARE UNDERSIZED, WORN, DAMAGED, OR HOSES OTHER THAN THOSE WE RECOMMEND ARE USED.**

*When ordering parts or corresponding with us about this machine, please provide the following information as follows:*

Machine Model No. \_\_\_\_\_

Machine Serial No. \_\_\_\_\_

## INTRODUCTION

Several safety features are on the **Electric Volu-Matic™SE** machine to ensure operator safety. Study the safety section thoroughly so that all the features concerning safety are understood. Keep all these features functional during machine operation.

This introduction is presented to provide a basic description of the function and purpose of the **Electric Volu-Matic™SE**.

The **Electric Volu-Matic™SE** machine is principally designed to blow insulating materials into attics of manufactured housing, and can also be configured to blow side walls. The insulation material manufacturer's instructions prevail when it comes to installing their product, since they guarantee the final results.

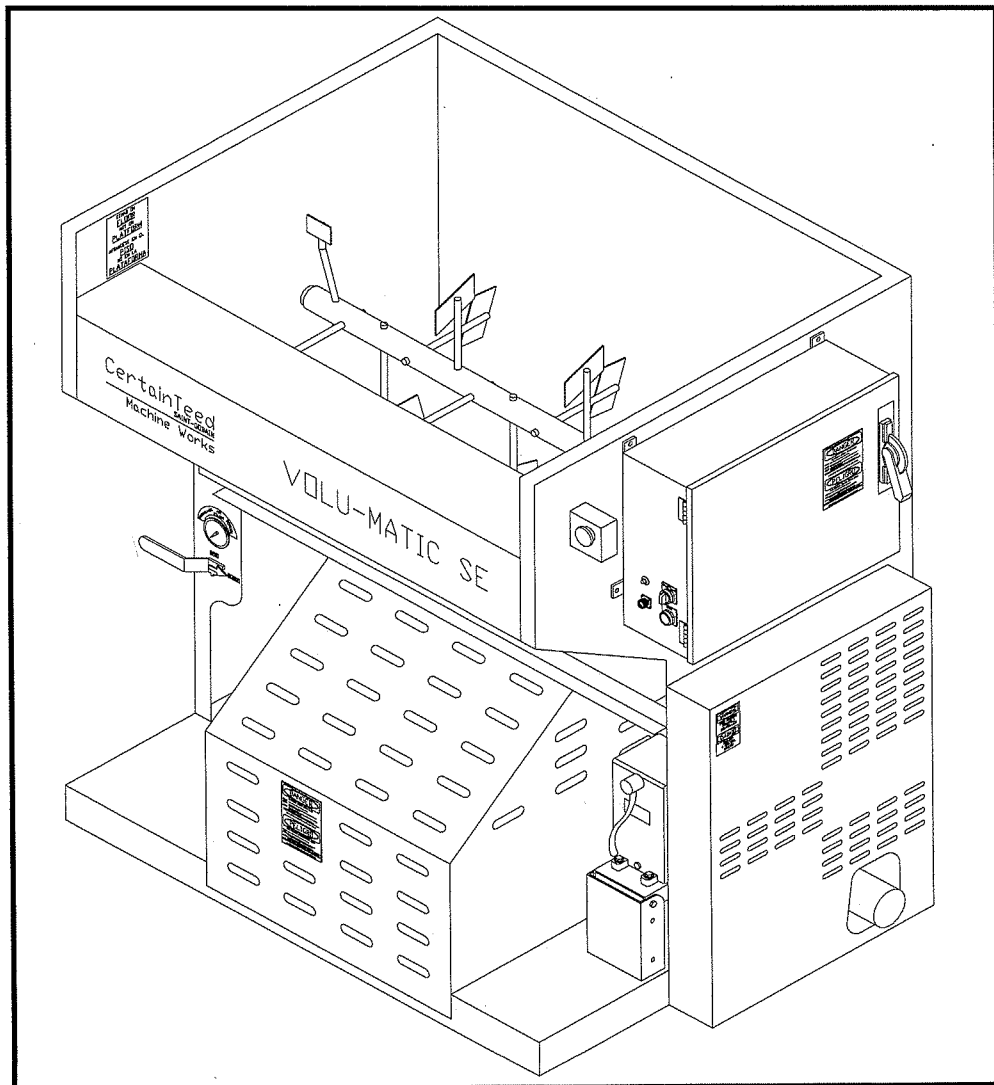

The ***Electric Volu-Matic™SE*** machine is normally installed in Manufactured Housing plants or Research & Development and Quality Control labs. The belt driven power train that drives all machine mechanisms, includes electric motors that provide separate control of various functions on the machine. To allow the person installing the insulation full control of the machine, a 24-volt electrical remote control system is provided, which operates through the provided hard wire remote cord and toggle switch. The ***Electric Volu-Matic™SE*** controls provide independent control of both the air that blows the material down the hose to its destination, and the machine mechanisms that condition and feed the insulating material into that air stream. The machine can be set at different speed settings with the transmission to match the applicators ability and/or material characteristics.

The 24-volt electrical remote control circuit is controlled through a transformer located in the electrical panel. The electrical control circuit is protected with adequately sized fuses. When the remote cord switch is moved toward the cord, power is sent through the blower remote control relay's internal coil. This causes the normally open contacts in the relay to close sending power to the blower motor starter. When the remote cord switch is moved toward the end of the switch housing, power flows to the blower and mechanism relay's internal coils. This causes the normally open contacts to close sending power to the respective motor starters. The toggle switch in the remote cord housing is labeled to identify these machine functions.

The hopper area where material is deposited into the machine has a circulator to open and stir the material, and an auger at the bottom for material feed. Material exits the auger and is conditioned by the shredder before entering the airlock feeder. The airlock feeder deposits the material into the air stream where it enters the hose and flows to the hose exit.

Another feature on the ***Electric Volu-Matic™SE*** machine is a slide gate that when adjusted, can lengthen the time the material is in the hopper area, which conditions the material. The slide gate is used to control both feed rate and material conditioning during side wall applications. Air volume is controlled independently with a manually operated valve, to help optimize material coverage.

**BEFORE YOU RUN THIS MACHINE...**  
***PLEASE STUDY THE REST OF THIS MANUAL.***

## SAFETY

The *Electric Volu-Matic™ SE* Insulation Blowing Machine has full guarding and electrical disconnects for your safety. Every *Electric Volu-Matic™ SE* machine has this warning displayed in a prominent place. **Do not remove, modify, or deface the warning label!**



**TO PREVENT SERIOUS BODILY INJURY**

**NEVER** REPAIR OR SERVICE THIS MACHINE WHILE IT IS RUNNING.

**NEVER** REPAIR OR SERVICE THIS MACHINE WITH THE POWER CABLE PLUGGED IN- ALWAYS THROW THE SAFETY DISCONNECT SWITCH AND UNPLUG THE POWER CABLE.

**NEVER** ATTEMPT TO RETRIEVE FOREIGN OBJECTS FROM THIS MACHINE UNLESS IT IS STOPPED, THE SAFETY DISCONNECT SWITCH THROWN AND THE POWER CABLE UNPLUGGED.

IT IS THE EMPLOYERS RESPONSIBILITY TO IMPLEMENT THE ABOVE, PROVIDE PROPER SAFETY EQUIPMENT FOR THE OPERATORS OF THIS MACHINE AND TO MAINTAIN THE FACTORY INSTALLED SAFEGUARDS.

**DO NOT DEFACE OR REMOVE THIS SIGN FROM THIS MACHINE**



**PARA PREVENIR LESIONES FÍSICAS SERIAS**

**NUNCA** REPAIRE O DE SERVICIO DE MANTENIMIENTO A ESTA MAQUINA MIENTRAS ESTE ACTIVADA.

**NUNCA** REPAIRE O DE SERVICIO DE MANTENIMIENTO A ESTA MAQUINA CON EL CABLE DE TENSIÓN ELECTRICA ENCHUFADO - APAGUE EL INTERRUPTOR DE SEGURIDAD Y DESENCHUFE EL CABLE DE LA TENSIÓN ELECTRICA.

**NUNCA** INTENTE RECUPERAR OBJETOS EXTRAÑOS DE ESTA MÁQUINA A MENOS QUE LA DESACTIVE, APAGUE EL INTERRUPTOR DE SEGURIDAD Y DESENCHUFE EL CABLE DE LA TENSIÓN ELECTRICA.

EL PATRÓN ES RESPONSABLE DE PONER LO ANTEDICHO EN EJECUCIÓN, DE PROVEER EL EQUIPO DE SEGURIDAD APROPIADO PARA LOS OPERADORES DE ESTA MÁQUINA Y DE MANTENER LAS SALVAGUARDAS INSTALADAS DE FÁBRICA.

**NO DESFIGURE NI REMUEVA ESTE AVISO DE ESTA MÁQUINA**

**WARNING: IF ANY FOREIGN OBJECT SHOULD ENTER THE MACHINE; PUSH AN EMERGENCY STOP BUTTON IN (OFF), TURN OFF THE DISCONNECT SWITCH AND SELECTOR SWITCH, UNPLUG THE REMOTE CORD, AND SHUT THE MAIN POWER SOURCE DOWN BEFORE RETRIEVING THE OBJECT. NEVER REACH INTO THE MACHINE WHILE IT IS IN OPERATION.**

Other warning signs, caution signs, and danger signs are displayed so that the operator is aware of other hazards associated with the use of the machine. You will see the following warnings on the machine. Do not remove, modify, or deface the warning labels!



The purpose of this sign is to make the operator aware that they may lose their balance and fall.

All **Electric Volu-Matic™SE** machines are factory equipped with side, front, and rear guards. The top of the machine is not guarded for normal operation. If the machine is installed in a manufacturing plant or other type of building where PEOPLE are above the machine hopper, a top guard will have to be equipped.

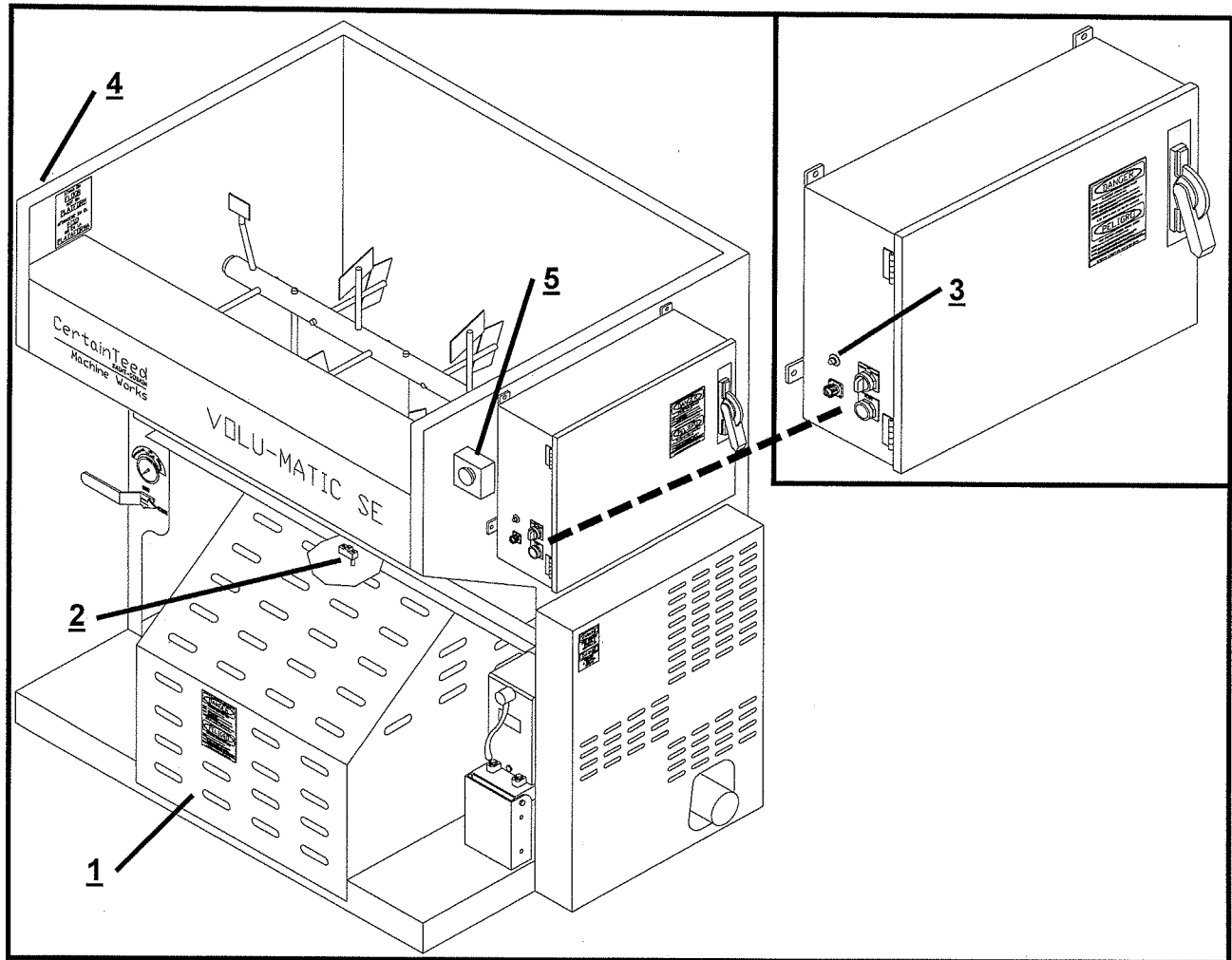

The front guard **1** is designed to hinge up for access to your machine for maintenance and troubleshooting. **This guard must never be opened while your *Electric Volu-Matic™SE* machine is in operation - there are shafts under the guard, which are still rotating.** If this guard is opened, a safety switch **2** is mounted to the guard which will stop the electric motors that drive chain driven mechanisms and the blower. **If the motors do not shut off or stop when the guard is lifted up, you should request that maintenance be performed on the safety interlocks.** You will have to push the reset button **3** in order to restart the machine after the guard is closed. If the safety switch or guard should become damaged, replace them to ensure safety while operating your **Electric Volu-Matic™SE** machine.



There are two emergency stop buttons **4 & 5** that will completely shut the machine down. Either red button will stop both electric motors that drive all machine mechanisms when pushed in (off) overriding all other controls. **If the mechanisms do not shut off or stop when either button is pushed, request that maintenance be performed on the safety interlocks.** The emergency stop buttons must be pulled out (on) for normal operation. You will have to push the reset button **3** in order to restart the machine after the emergency stop is pulled back out.

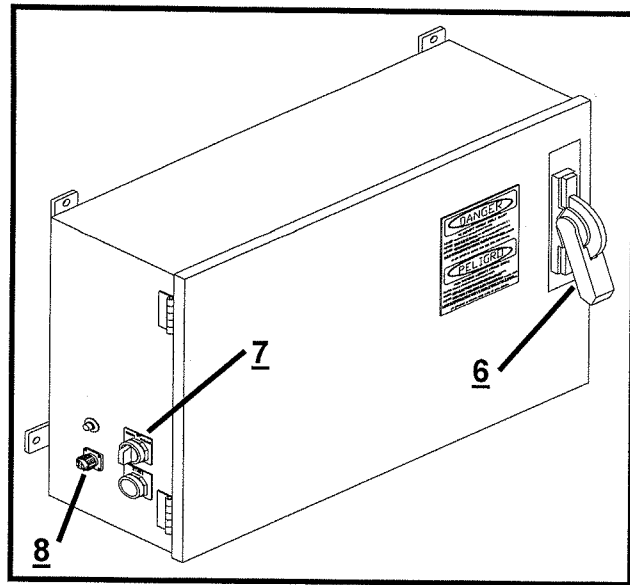

**“Knowledge of the location and function of these emergency stops is emphasized.”**

These buttons should be used for any of the following type of emergencies:

- unauthorized individual getting too close to the machine.
- objects falling into machine.
- a machine component breaks.
- a material hose becomes disconnected.
- anything requiring immediate stopping of the machine.

During machine operation, always move the disconnect switch **6** to the off (down) position, move the selector switch **7** to the off (middle) position, and unplug the remote cord from the receptacle **8** before removing any guards for any reason!

During machine operation, always stand on the floor to deposit material into the hopper. Under no circumstances should your hand, arm, stick, or broom be used to move or force feed material down into the hopper. The **Electric Volu-Matic™ SE** machine is a self-feeding design requiring no outside assistance for smooth flow.

Operators should wear hearing protection if the machine noise makes them uncomfortable or noise level exceeds acceptable standards. CertainTeed Machine Works recommends that the operator wear an “approved” dust mask or respirator for their protection. Safety features are incorporated into the **Electric Volu-Matic™ SE** machine to protect from serious injury. Operate your machine according to the outlined instructions in this manual with all safety features in place and working properly. Operating the machine in an unsafe manner can result in serious injury.

## INSTALLATION

The **Electric Volu-Matic™ SE** is designed for operation in a manufacturing or industrial plant. Use the following guide when considering location in the plant for machine operation.

1. Locate machine to facilitate the blowing operation. Consider minimum hose length suggested for operation and the hose routing to prevent kinks in the hose.
2. Make sure adequate room is available for loading the machine. See operation section.
3. Refer to the following drawing for mounting hole locations and electrical power cord connection. Remove all crating from the machine frame.

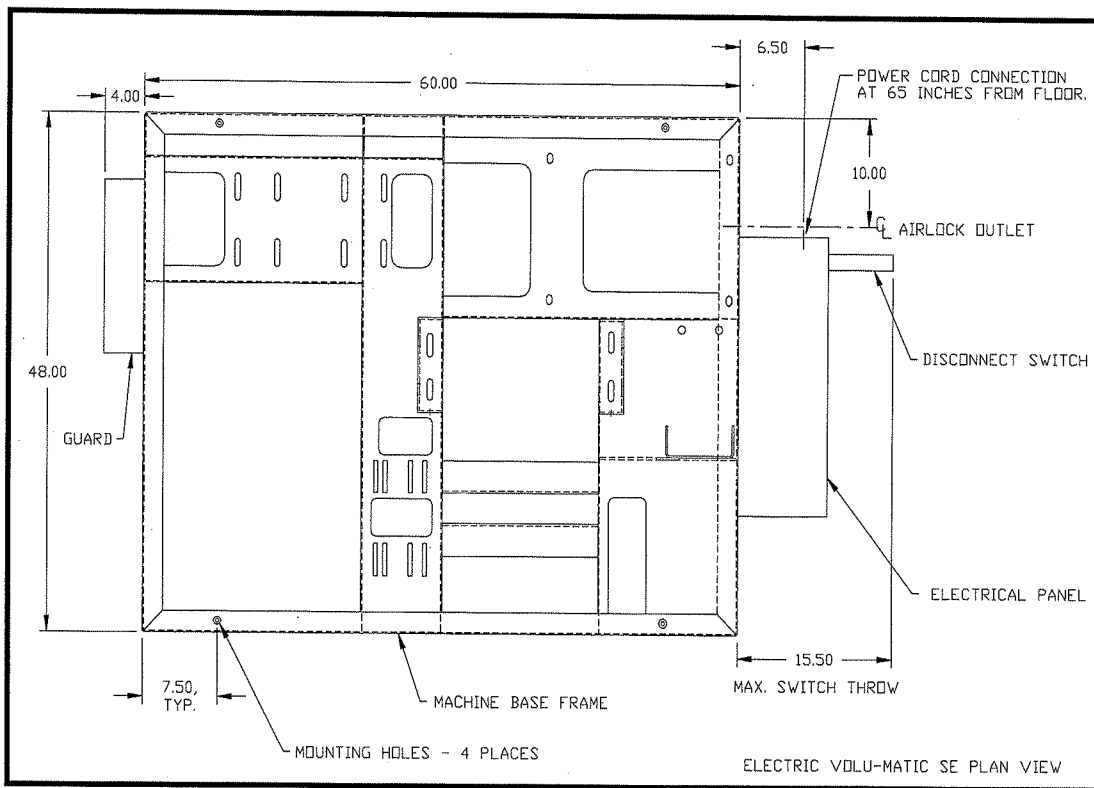

4. Purchase and install a top guard if the **Electric Volu-Matic™ SE** is located in a manner where PEOPLE are above the machine.
5. Have a qualified industrial electrician connect power to the disconnect switch and ground to electric panel through strain relief. Check the following chart for proper wire size and type.

<u>WIRE LENGTH</u>	<u>WIRE SIZE</u>	<u>WIRE TYPE</u>
50 FEET	8 / 4	THHN OR THW
100 FEET	6 / 4	
150 FEET	6 / 4	

## OPERATION

### Preliminary checks

1. Check the following table for the proper hose size, type, and length for a particular operation. All hose couplings must be thin wall, 1/16 inch maximum, to minimize restrictions. Thin wall couplings can be purchased from CertainTeed Machine Works.

MATERIAL	OPERATION	HOSE DIAMETER	HOSE LENGTH	HOSE TYPE
CELLULOSE FIBERGLASS ROCKWOOL	OPEN BLOW	3 ½" MINIMUM	150' MINIMUM	MARK II
CELLULOSE FIBERGLASS ROCKWOOL	SIDE WALL	2 ½" MINIMUM 3" MINIMUM 3" MINIMUM	150' MINIMUM	MARK II

2. Make sure that hopper area is empty.
3. Check for presence of oil from the blower and transmission indicating a leak.
4. Check material conditioning slide and air bleed valve position. Check the recommended start settings chart for proper position.
5. Make sure all guards are in place and securely latched.

### Preliminary Start-up Checks

1. Move the disconnect handle **6** to the up (on) position and make sure the emergency stop buttons **4 & 5** are pulled out (on) and press the reset button **3**. Leave the selector switch **7** in the off (middle) position. Clear the area in front of the airlock feeder outlet **9** for testing. Press the green start button **10** to check blower rotation, see arrow on drive motor. Check that air does exit the airlock outlet. Turn the selector switch to machine to check the mechanism motor rotation. All **Electric Volu-Matic™ SE** machines are pre-wired for the correct rotation at the factory. If rotation is incorrect, have a qualified industrial electrician interchange two current carrying leads at the power source to change rotation.
2. With all rotations correct, shut the machine down completely. Place the transmission **11** into first gear, see getting started section.

3. Move the toggle switch **12** to the center (off) position and plug the remote cord **13** shipped with new delivered machines into the receptacle **8**. This is a twist lock connection.

4. Power up the machine as in step one. Press the green start button **10** and the blower will start. Turn selector switch **7** to remote and the blower will stop. Cycle the toggle switch in the remote cord housing toward the cord and the blower will come on. With the blower operating satisfactorily, cycle the switch toward the end of the housing and the blower and machine mechanisms will operate simultaneously.

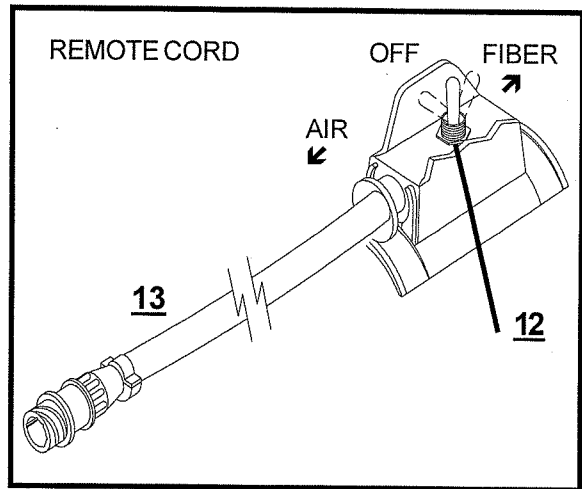

5. Become knowledgeable about the components of the **Electric Volu-Matic™ SE** machine. Engage and disengage the remote cord noticing the drives start and stop. With machine running, push one emergency stop button and check that the drives stop. Pull emergency stop button out, push the reset button and start the machine again. Push in the other emergency stop button and check that the drives stop. If the remote toggle switch was cycled off, then cycle the toggle switch for the drives to come on.

6. For any problems encountered during preliminary start-up procedures, check the Troubleshooting section or call CertainTeed Machine Works at 800-237-7841.

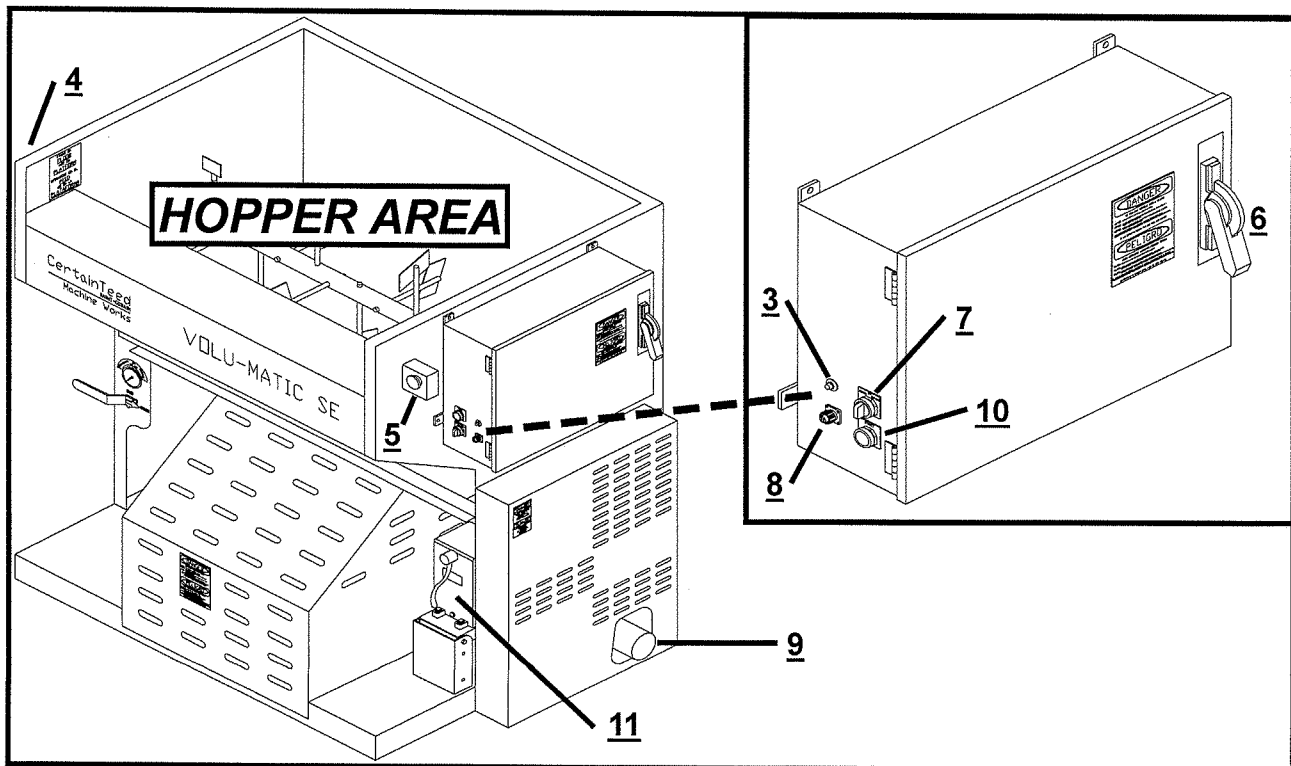

## ELECTRIC VOLU-MATIC™ SE RECOMMENDED START SETTINGS CHART

<u>OPERATION</u>	<u>MATERIAL</u>	<u>SLIDE GATE</u>	<u>TRANSMISSION GEAR</u>	<u>AIR BLEED PRESSURE</u>
OPEN BLOW	CELLULOSE	16"	3rd	2.0 – 3.5 PSI
	FIBERGLASS	16"	3rd	2.0 – 3.5 PSI
	ROCKWOOL	12"	2nd	4.5 – 5.5 PSI
SIDE WALL	CELLULOSE	8"	1st	1.0 – 2.5 PSI
	FIBERGLASS	8"	2nd	1.0 – 2.5 PSI
	ROCKWOOL	6"	1st	1.5 – 1.75 PSI

**NOTE 1: USE THESE SETTINGS AS A STARTING GUIDE ONLY. VARIATIONS BETWEEN MATERIALS OF THE SAME TYPE AND VARIATIONS BETWEEN BATCHES FROM THE SAME MANUFACTURER MAY REQUIRE DIFFERENT SETTINGS THAN THOSE SUGGESTED. REMEMBER, THE MATERIAL MANUFACTURER'S INSTRUCTIONS PREVAIL SINCE THEY GUARANTEE THE FINAL RESULTS.**

**GENERAL INSTRUCTIONS:**

1. VARY THE AIR BLEED PRESSURE FIRST. IF YOU CANNOT GET THE DESIRED RESULTS BY OPENING OR CLOSING THE AIR CONTROL LEVER HANDLE, THEN...
2. VARY THE SLIDE GATE NEXT. IF YOU CANNOT GET THE DESIRED RESULTS BY CLOSING OR OPENING THE SLIDE GATE, THEN...
3. GO TO THE NEXT HIGHEST OR LOWEST SPEED ON THE TRANSMISSION. IF YOU CANNOT GET THE DESIRED RESULTS CHANGING THE SPEED, THEN...
4. ADD OR REMOVE STATOR BAR. IF YOU CANNOT GET THE DESIRED RESULTS BY ADDING OR REMOVING THE STATOR BAR, THEN START WITH VARYING THE AIR PRESSURE AGAIN.

## Getting Started

1. Use the preliminary and start-up checks as a check list on your **Electric Volu-Matic™SE** machine each day. Connect hose firmly with band clamps and make sure the hose does not have a short radius bend. A short radius bend will result in poor coverage, excessive hose and feeder wear, and/or plugged hoses. Use thin wall couplings and reducers, 1/16 inch maximum, to minimize restrictions. See drawings on the next page.

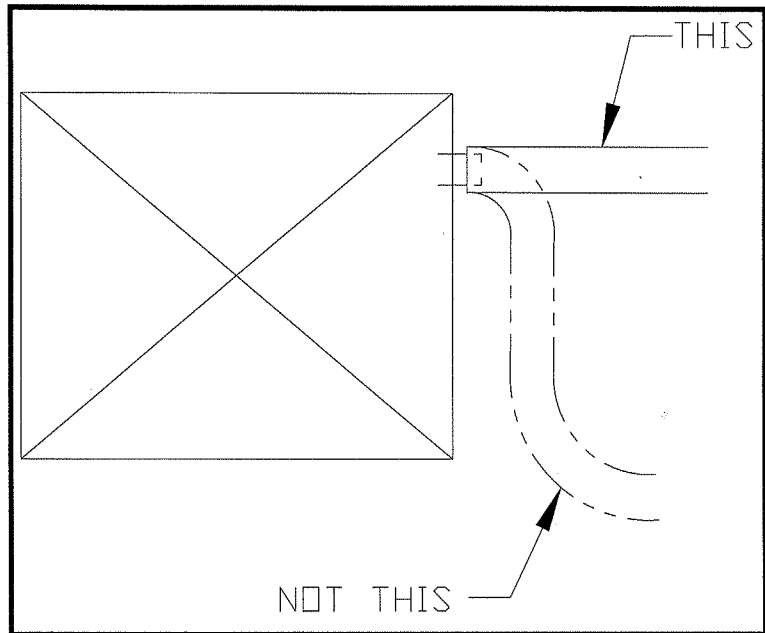

The **Electric Volu-Matic™SE** machine will not perform to specifications when held back by undersized and restrictive hoses, couplings, and reducers. For open blow operations, use a 25 foot to 50 foot length of 4 inch diameter hose at the air lock feeder outlet connection if excessive high air pressure is experienced using all 3-1/2 inch diameter hose.

Repeated warnings about choice of hose may seem to be an attempt to sell our brand, but we must stress the importance of proper hose selection for the type of material and operation. A rough bore corrugated hose is necessary for blown fibers since smooth bore rubber or plastic will roll shredded material into small tight balls. Your **Electric Volu-Matic™SE** machine has been engineered, when properly adjusted, to condition fibers for optimum coverage. Improper hose selection will degrade fibers conditioned by the machine and reduce insulation value in blown material. Do not deviate from hose diameters, types, or length, as specified in the table.

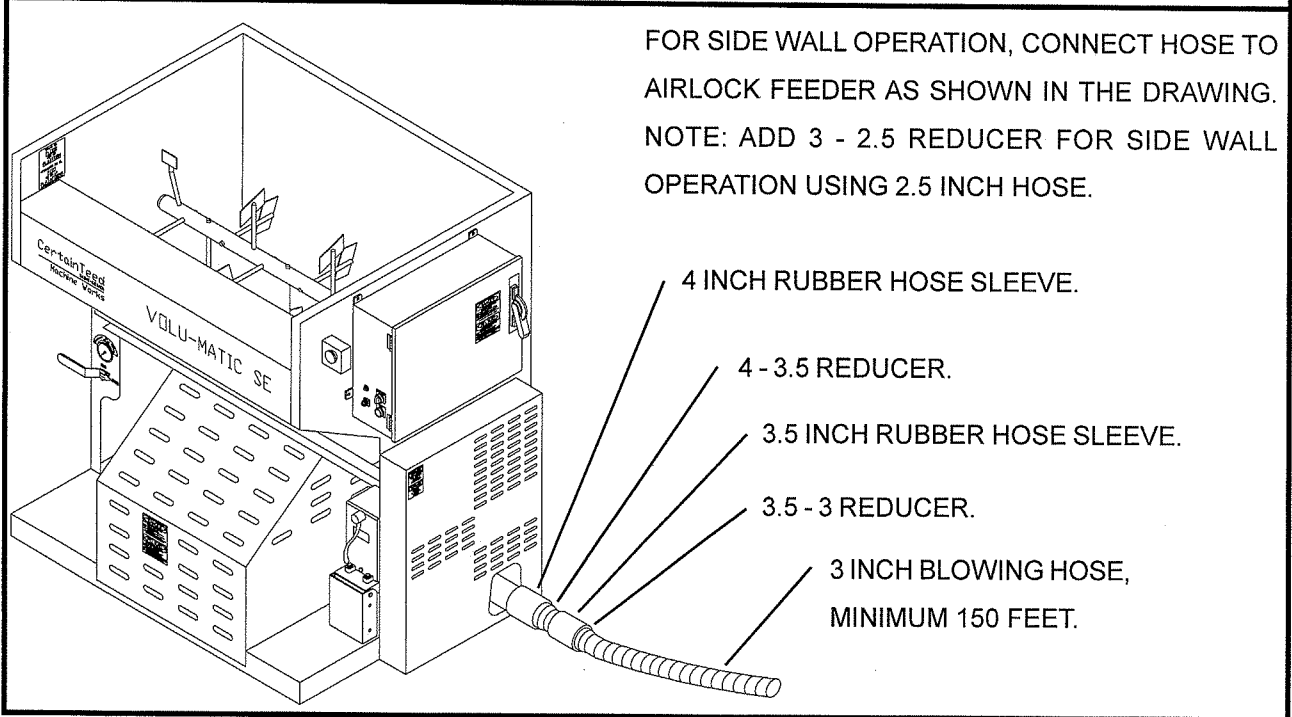
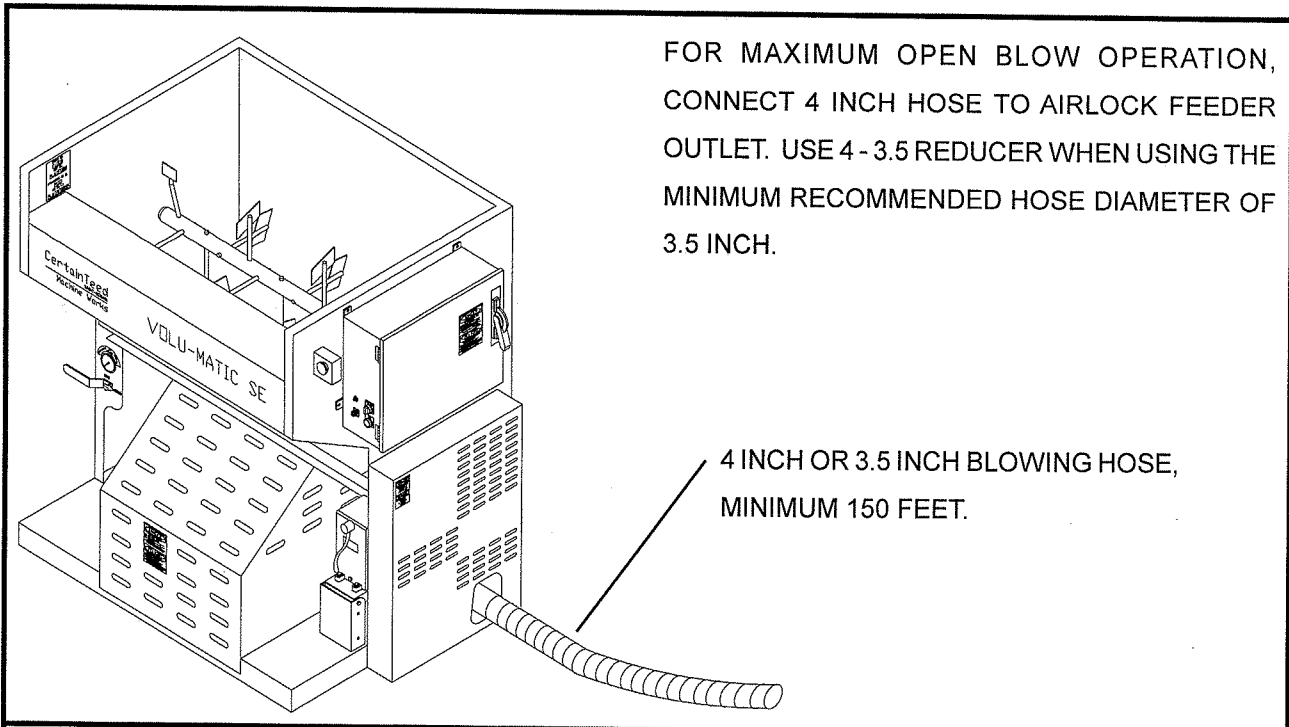

2. Make sure the emergency stop buttons **4 & 5** are pushed in (off) and the remote cord toggle switch **12** is in the center (off) position.
3. Use the recommended start settings chart to adjust machine for the type of insulation you are using and particular operation.

4. Air flow rate may be controlled with the air bleed control valve **14** while monitoring system pressure on the air gauge **15**. The system back pressure must be read while the **Electric Volu-Matic™ SE** machine is operating with full length and proper hose while material is being blown.

Always start the adjustment with the air bleed control valve in the fully closed position. If the air flow and pressure deliver the desired results with the valve closed, then do nothing to the valve. As you begin to open the valve, air is bled off from the exit of the blower preventing flow of all air to the airlock feeder. As you open the valve, be careful to not open completely during open blow or the blowing hose could clog because of insufficient air volume.

**CAUTION: AS YOU OPEN THE VALVE, BE CAREFUL NOT TO OPEN COMPLETELY DURING OPEN BLOW OPERATION OR THE BLOWING HOSE COULD CLOG BECAUSE OF INSUFFICIENT AIR VOLUME.**

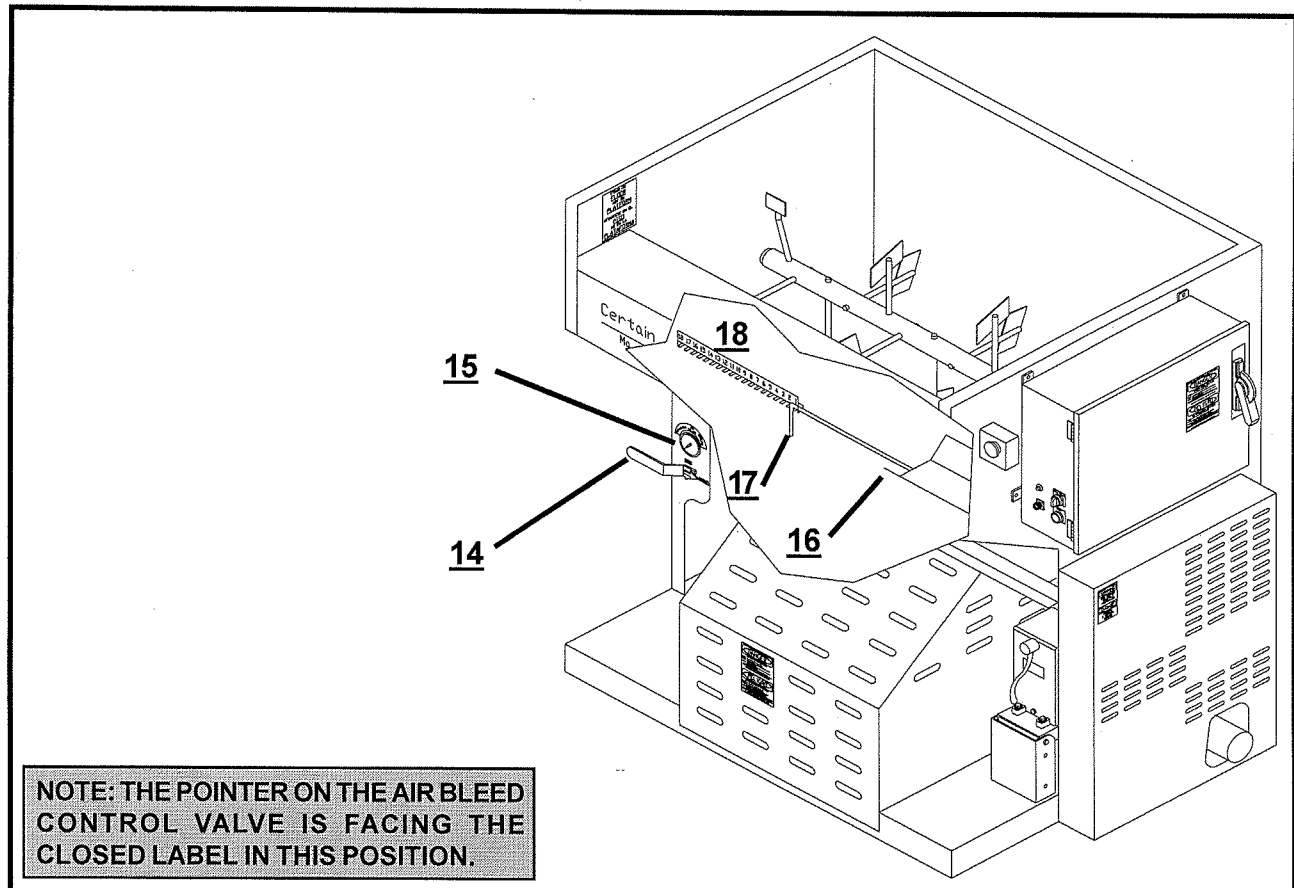

5. To adjust the slide gate **16**, refer to the chart and select the proper setting for the material to be blown and particular operation. Lift the handle **17** out of the notch and move to the left to open the slide gate. Place handle in notch that matches with the desired setting on the scale **18**. The scale is calibrated in inches of opening.



6. To adjust the transmission 11, refer to the chart and select an appropriate gear for material and type of operation. Shift the lever 19 into gear in accordance with decal instructions on the machine front panel. Since the transmission is not synchronous, it may be necessary to pull the gears through by hand using the pulley 20 so that gears mesh allowing you to change them. This should never be attempted or gears shifted while the machine is operating.

**WARNING: NEVER ATTEMPT TO CHANGE GEARS WHILE THE *Electric Volu-Matic™ SE* MACHINE IS IN OPERATION. ALWAYS CHANGE GEARS WHEN THE MACHINE IS COMPLETELY SHUT DOWN. FAILURE TO DO SO CAN RESULT IN SERIOUS PERSONAL INJURIES OR A SEVERELY DAMAGED TRANSMISSION.**

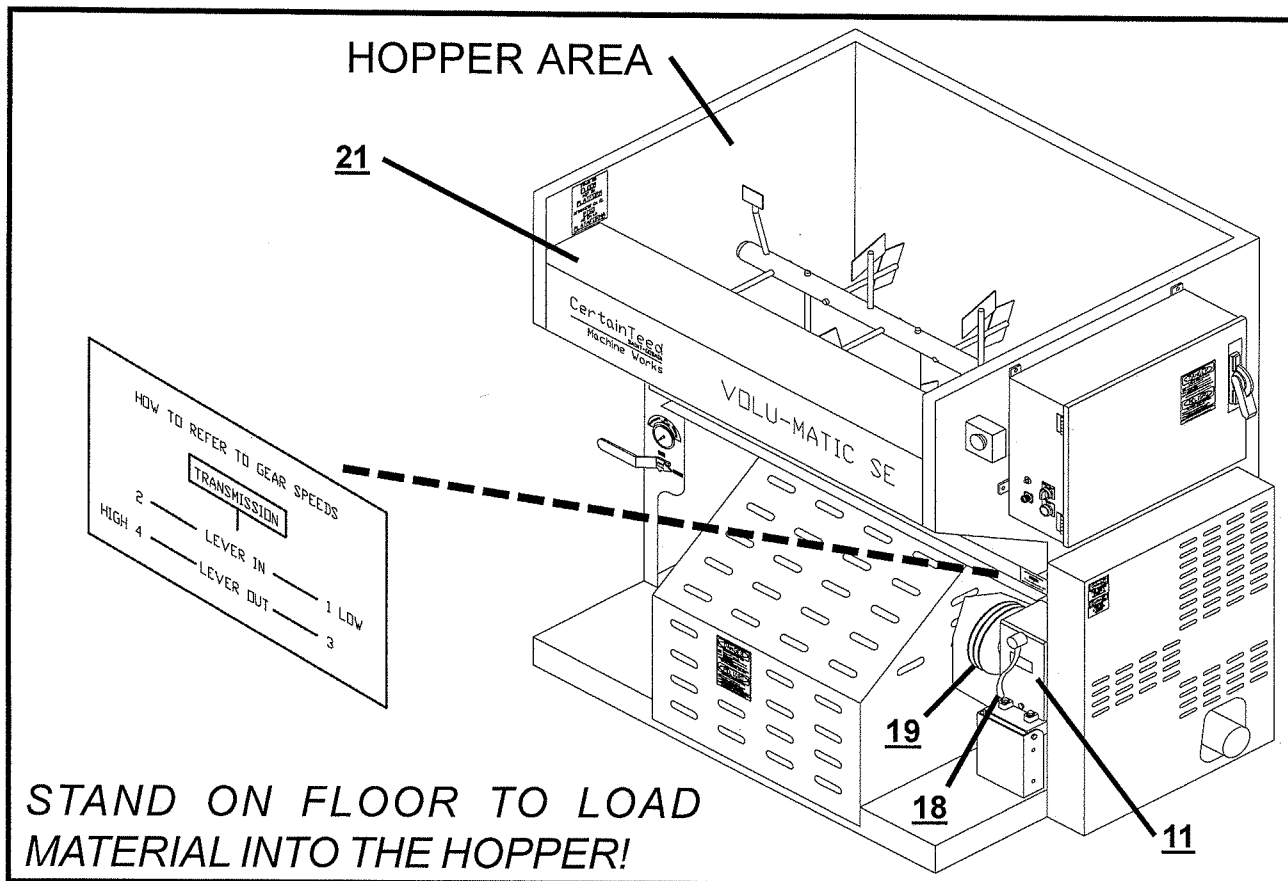

7. Load the machine from a standing position on the floor depositing bags of material on the shelf 21. Do not build scaffolding or use a foot stool to load material into the *Electric Volu-Matic™ SE* machine. This moves the operator closer to the rotating components in the hopper and provides a way to lose balance and fall.

Load three to four bags of material into the hopper being particularly careful not to leave pieces of bag in the material since this will clog and stall the machine.

**WARNING: DO NOT ATTEMPT TO REMOVE ANY FOREIGN OBJECT FROM THE MACHINE UNTIL IT IS COMPLETELY SHUT DOWN; DISCONNECT SWITCH OFF, EMERGENCY STOP BUTTONS PUSHED IN, SELECTOR SWITCH OFF, AND THE REMOTE CORD UNPLUGGED. FAILURE TO DO SO WILL RESULT IN SERIOUS INJURIES BY THE ROTATING COMPONENTS IN THE HOPPER OR ON THE MACHINE.**

8. Start the machine for operation.
9. Take the end of the blowing hose and remote cord to the job's starting point. Engage remote cord for air and material to begin the insulation blowing process.
10. Upon completion of open blow operation, use air only function for the following;
  - clear all material out of hose.
  - level off insulation mounds.
  - blow off duct work and clear out air handler drip pan.
  - blow material from recessed lights.
  - blow material out of soffits

### **Coverage**

Coverage may be defined as the maximum allowable square feet covered per bag at a minimum specified depth and weight per square foot at a given "R" value. A manufacturer might recommend that the material be blown at a rate of 79 sq./ft. per bag at a depth of 8 3/4 inches and a weight 0.444 lbs. sq. ft. to achieve an insulation value of R-19. If you opened a bag of material and hand distributed it to a depth of 8 3/4 inches, it would only cover 15 - 16 sq./ft. Fiber must be worked or conditioned by your **Electric Volu-Matic™ SE** machine to achieve coverage of 79 sq./ft. per bag.

Coverage decreases when feed rates are too low and material is overworked by the machine mechanisms (or the wrong hose is used) rolling the fibers into tight little balls. Coverage will also decrease if feed rates are too high, allowing material to pass through the machine before it has been opened to the proper density.

*continue...*

An option to coverage problems can also be controlled to some extent with the use of a stator bar in the shredder housing. Remove cover plate **22** and insert stator bar **23** making sure shredder hammers clear pins before bolting down. This adjustment should be done only after various settings of the air bleed control valve, slide gate, and transmission speed do not gain desired results. The stator bar can help increase coverage, but it can also decrease coverage and slow the feed rate of the machine.

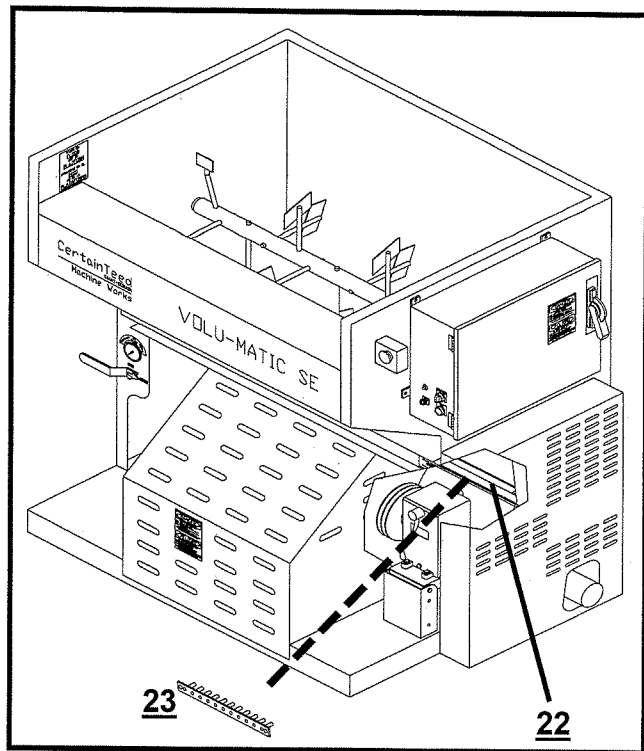

## Electrical System

The following is a description of the electrical system on the machine. An electrical schematic is included in the troubleshooting section.

Power is supplied by the buildings electrical distribution to the disconnect switch. When the disconnect switch is moved to the on (up) position, electricity flows through the switch and fuses while providing power to the control transformer, selector switch, relays, and start button. The emergency stop buttons must be pulled out and the guard closed against the safety switch and reset button must be pushed for this electricity flow. With the selector switch in the off position, pressing the green start button will start the blower motor. Move the selector switch to the machine position and both motors will start. Move the selector switch to the remote position and both motors will not start until the remote control cord switch is moved from the center position.

The 24-volt electrical remote control circuit is controlled through a transformer located in the electrical panel. The electrical control circuit is protected with adequately sized fuses. When the remote cord switch is moved toward the cord, power is sent through the blower remote control relay's internal coil. This causes the normally open contacts in the relay to close sending power to the blower motor starter. When the remote cord switch is moved toward the end of the switch housing, power flows to the blower and mechanism relay's internal coils. This causes the normally open contacts to close sending power to the respective motor starters.

## **PREVENTIVE MAINTENANCE**

### **General**

**Make sure all power sources are off before attempting any maintenance procedures.**

Check for loose nuts and bolts, check for slack and condition of chains and belts, and check for oil leaks, especially after the first few days of operation. Keep the machine clean.

### **Daily**

1. Check and clean the blower air inlet screen as required during operation. Keep this screen clean.
2. Visually inspect and remove any foreign objects that may have entered the machine such as pieces of bag, rags, razor knife, etc.
3. Make sure guard limit switch and emergency stop buttons are functional.
4. Check that the shredder area inspection window is not cracked.

### **Weekly**

1. Check chain and belt tension on the machine.
2. Check the oil level in the blower and transmission.

### **Airlock Feeder**

The airlock feeder will require periodic maintenance to prolong the life of the assembly since steel will wear when abrasive type materials and air velocity are mixed. The rubber feeder seals must be changed every 250 hours of operation or approximately every 1 ½ months if the machine is operated 8 hours a day 5 days a week. Additionally, the seals need to be replaced if problems are experienced with loss of air pressure and blow-by occurs during machine operation. Blow-by is a term used when material seems to blow back into the hopper area while the auger tries to meter the material into the shredder area. Failure to change seals on schedule will result in excessive wear and replacement of the feeder assembly.

Change the *Electric Volu-Matic™ SE* Airlock Feeder Seals as Follows:

- A. Make sure you have a complete set of seals (6) before the job is started.
- B. Make sure all power is disconnected; disconnect switch off, selector switch off, emergency stop buttons pushed in, and remote cord unplugged.
- C. Remove necessary guards to do the job after power is disconnected, make sure that all guards are installed and secure when job is complete.
- D. Once the outlet end plate is removed, check for excessive wear on the feeder barrel and end plate surfaces. New seals will not be effective in an excessively worn feeder. Inspect rotor for any wear and repair as required.
- E. Replace excessively worn or damaged feeder barrel, end plate and bearing seals for optimum performance from your *Electric Volu-Matic™ SE* machine. Excessively worn parts are considered to be when 25% of metal thickness has worn away.
- F. Supplies and tools for seal change:  
Set of six seals – seal part number A-39U-18, spare 1/4"-20 x 5/8" length grade 5 bolts and lock washers, spray silicon, never-seize shaft lube, penetrating oil, emery cloth, feeder crank hub and rod, dead blow hammer, pry bars, flat file, miscellaneous sockets, open end wrenches, and hex head Allen wrenches.

- 1. Loosen the set screws A in bearing collar on the inlet end plate only.
- 2. Move idler pulley B to left and tighten nut C. Remove drive chain and sprocket D at front of feeder. Remove mounting bolts E.

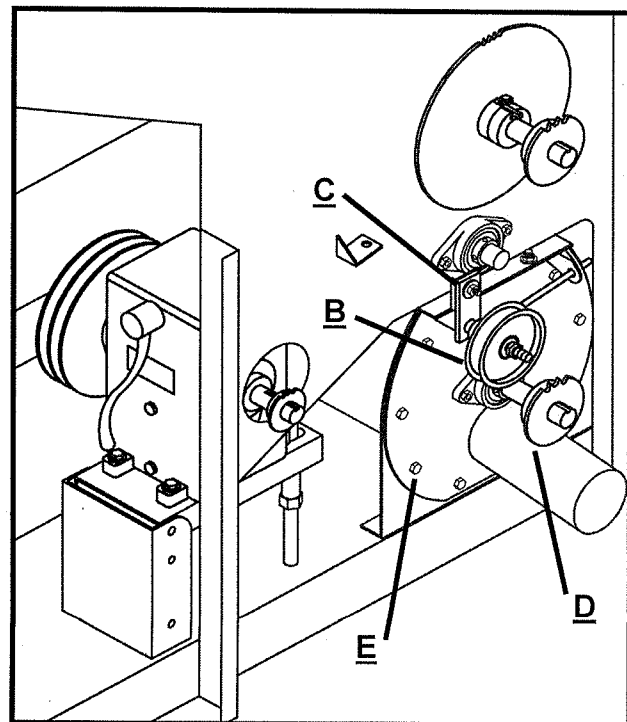
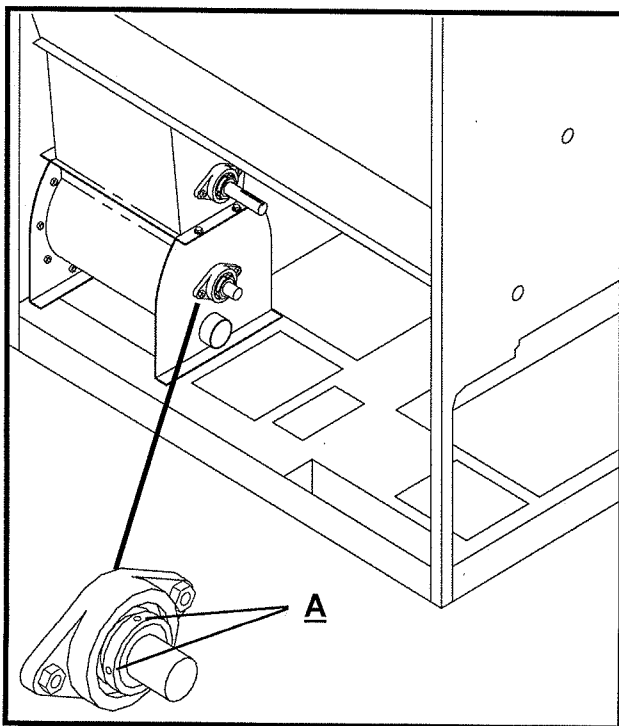

- Use pry bars **E** between end plate and feeder barrel to bring entire rotor assembly out. File and polish the rotor shaft. Loosen set screws in bearing collar and slide the end plate off rotor shaft.

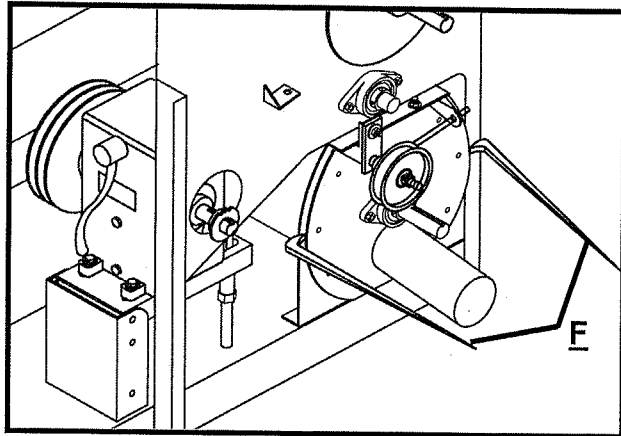

- Remove the bolts that hold the backing plate **G** and rubber seal **H** to the rotor assembly **I**. Clean the rotor vane surface **J** (opposite side) before placing in a new seal. Bolt on backing plate making sure not to over tighten, distorting the seal.

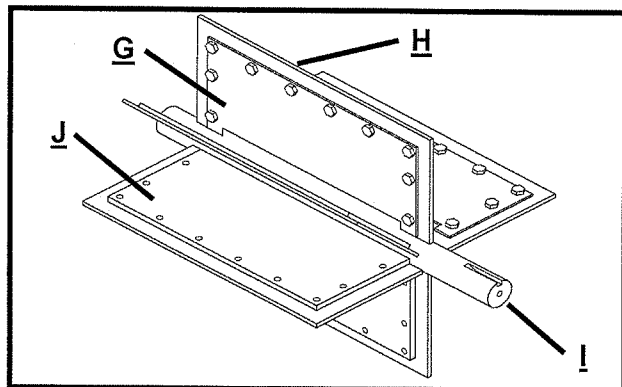

- Apply spray silicon lubricant to edges of new rubber seals and surface of feeder barrel. Apply never-seize lube on inlet bearing race.
- Insert rotor assembly into feeder barrel rotating counterclockwise using crank hub **K** and rod **L** while pushing with free hand. Make sure bearing seal at inlet end plate

does not pinch between rotor shaft and bearing race.

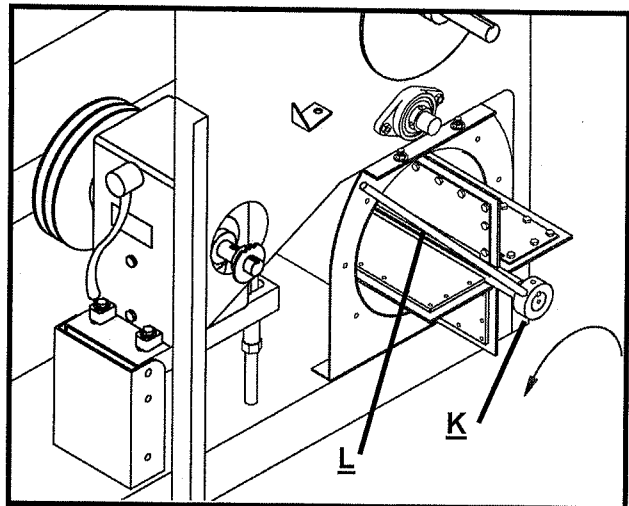

- Once rotor shaft enters the inlet end plate bearing, it might be necessary to use a dead blow soft hammer to fit rotor all the way in the feeder while rotating it. Push rotor as far in as possible with seals beginning to bend over on the side against the inlet end plate.
- Install mounting bolts and tighten half way down – rotate rotor – tighten bolts – rotate rotor – tighten bolts completely – rotate rotor.

Peer through outlet end plate to see if rubber seals break over against end plates evenly. Adjust as required by rotating rotor and tap with dead blow hammer. Tighten set screws in bearing collars when rotor is centered in the feeder barrel. Install drive components and any guards removed for service. Discard old seals.

## **Flanged Bearings**

Bearings should be lubricated every 6 months of operation if equipped with a grease fitting. Bearings without fittings are considered lubricated for life. Do not over lubricate. One to two pumps from a hand operated gun is sufficient.

## **Belts**

Do not use belt dressing. Belt dressing will collect material and cause the belts to slip and/or wear faster. There is no substitute for keeping belts dry, free of oil and grease, and tight. Replace worn and deteriorated belts as required. All belt driven components are equipped with take up adjustment.

## **Chains**

If abrasive materials are conveyed through the machine, do not lubricate the chain. This can cause the chain to collect material and wear the chain and sprockets prematurely. A chain lube is preferable if non-abrasive materials are conveyed through the machine.

## **Blower**

Check the oil level weekly in the blower by turning the brass valve 90 degrees to check. A small amount should appear indicating sufficient oil. Follow manufacturer's recommended maintenance schedule as specified in the enclosed blower manual. After 100 hours of operation, drain while warm and refill with fresh lubricant. Thereafter, change every six months or 1000 hours machine time. The bearings on the drive end of the blower should be grease lubricated once a month.

## **Transmission**

Check the oil level weekly in the transmission. The transmission is filled with **Mobil gear oil 626**. The proper oil level is marked at the front of the housing. After 100 hours of operation, drain while warm. Thoroughly flush housing with light flushing oil and refill with fresh lubricant. Thereafter, change and flush every six months or 1000 hours machine time.

**WARNING: ONLY A QUALIFIED INDUSTRIAL ELECTRICIAN TRAINED IN THE USE OF ELECTRICAL MEASURING EQUIPMENT AND ELECTRICAL SCHEMATICS SHOULD WORK ON THIS MACHINE PANEL. THIS IS A HIGH VOLTAGE MACHINE IN WHICH SERIOUS INJURIES CAN OCCUR TO NON-QUALIFIED EMPLOYEES. REFER TO THE ELECTRICAL SCHEMATIC AT THE END OF THIS SECTION.**

## **TROUBLESHOOTING**

### **1. Machine will not start.**

- A. Check if disconnect switch is at off position, selector switch at off position, emergency stops pulled out, reset button pressed.
- B. Check power cable connection.
- C. Check for blown fuse or tripped circuit breaker at power source.
- D. Check for blown fuse in machine panel.

### **2. Blower motor will not start.**

- A. Check blower motor fuses.
- B. Check if motor controller overload tripped.
- C. Check that remote cord is plugged in.
- D. Check remote control fuses.
- E. Check remote control circuit at latching relay.
- F. Check blower relay in remote control circuit.
- G. Remote control switch or cord defective - with selector switch off, push green start button.

### **3. Mechanism motor will not start.**

- A. Check mechanism motor fuses.
- B. Check if motor controller overload tripped.
- C. Check that remote cord is plugged in.
- D. Check remote control circuit at latching relay.
- E. Check mechanism relay in remote control circuit.
- F. Remote control switch or cord defective - try selector switch in machine position.



**4. Insufficient Air - Blower Is Operating.**

- A. Check that air bleed control valve 14 is not fully open.
- B. Check if blower air intake screen 24 is clogged.
- C. Check air stream hose connections.
- D. Material hose plugged.
- E. Check for blow-by indicating airlock feeder components (seals, end plate, etc.) worn out or damaged. To check for blow-by, the machine will have to be on for operation. Making sure the air bleed control valve 14 is

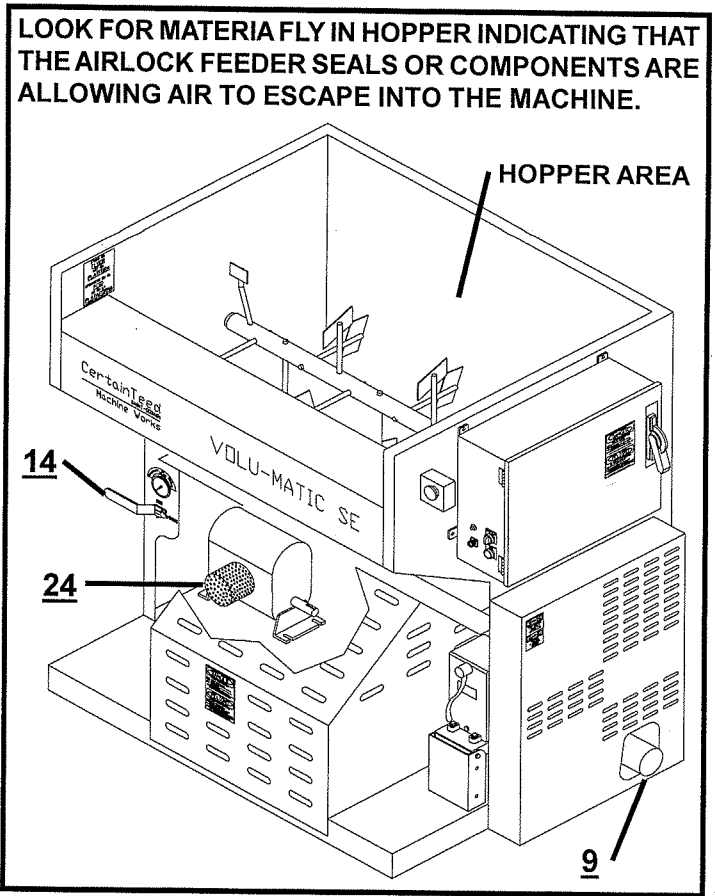

closed, cycle remote cord for air only. Then block exit of air at feeder outlet 9 (hold hose solid to ground or block with piece of wood) and check if air is blowing back up into the machine.

- F. Check if blower defective, worn, or damaged.

**5. No material flow - motor is operating.**

- A. No material in hopper.
- B. Transmission not in gear.
- C. Check shear key 25. Shut machine down completely and look for jams in machine if key continually shears.
- D. Check if slide gate is closed or adjusted in too far for material feed rate.
- E. Object restricting flow in the machine.
- F. Material hose plugged.

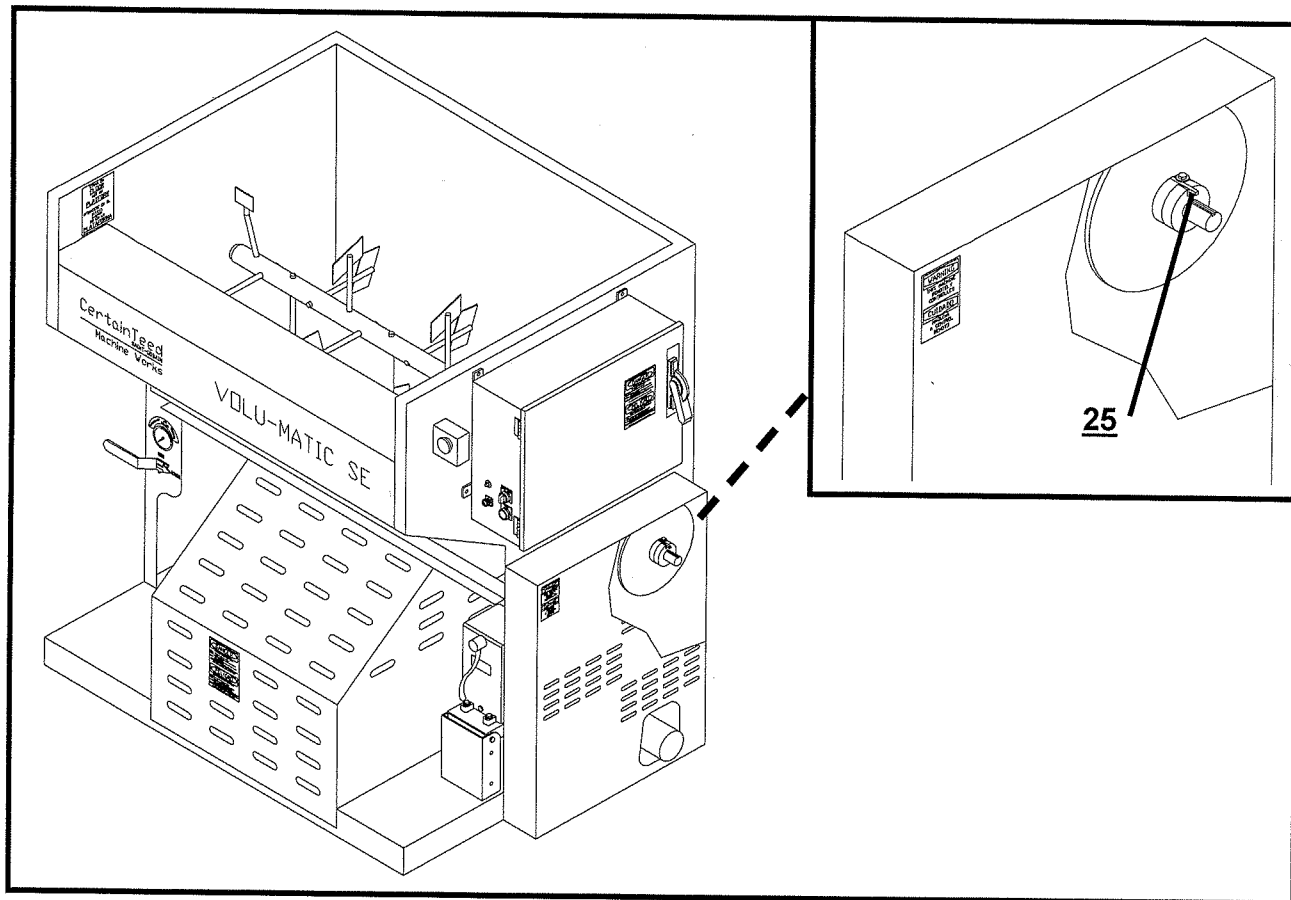

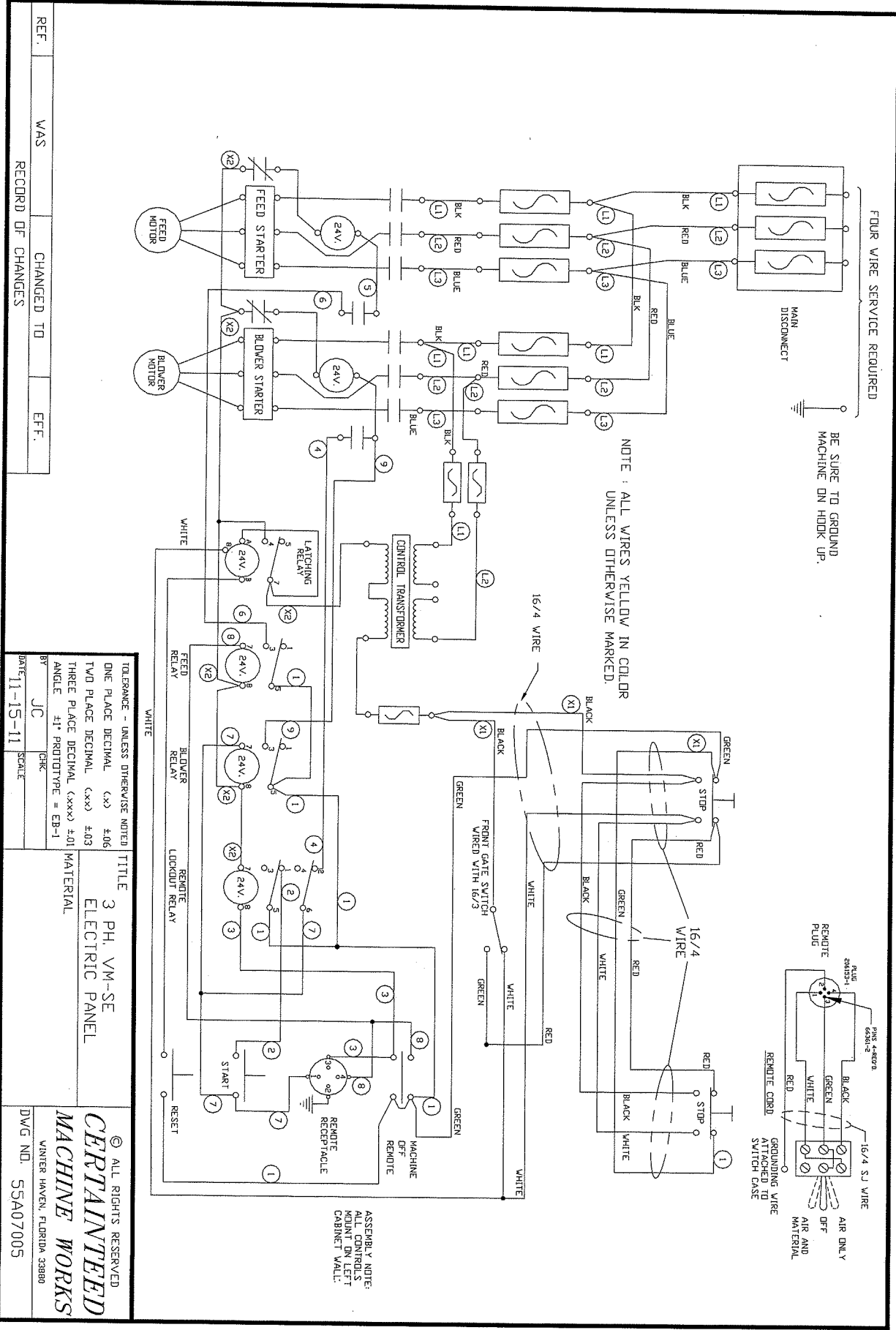

REF.	WAS	CHANGED TO	EFF.
	RECORD OF CHANGES		

TOLERANCE - UNLESS OTHERWISE NOTED	TITLE
ONE PLACE DECIMAL (.x) ±.06	3 PH. VM-SE
TWO PLACE DECIMAL (.xx) ±.03	ELECTRIC PANEL
THREE PLACE DECIMAL (.xxx) ±.01	
ANGLE ±1° PROTOTYPE = EB-1	
BY JC	CHECK
DATE 11-15-11	SCALE

MATERIAL	© ALL RIGHTS RESERVED
	<b>CERTAINTEED</b>
	<b>MACHINE WORKS</b>
	WINTER HAVEN, FLORIDA 33980
DWG. NO. 55A07005	

# PARTS DRAWINGS

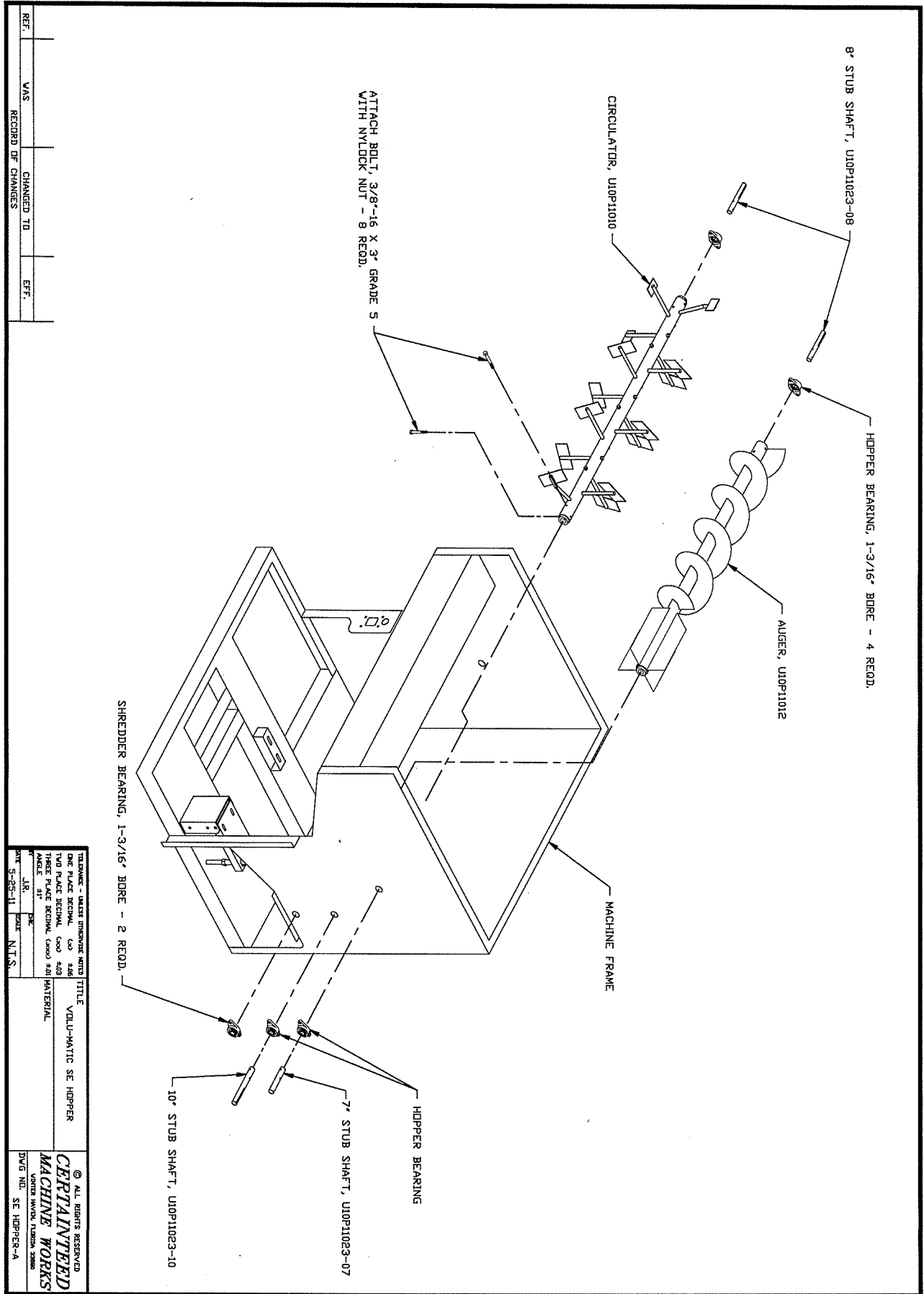

REF.			
VAS	RECORD OF CHANGES	CHANGED TO	EFF.

TOLERANCES - UNLESS OTHERWISE NOTED		TITLE
ONE PLACE DECIMAL, C99 4/16		VOLU-MATIC SE HOPPER
TWO PLACE DECIMAL, C99 4/16		MATERIAL
THREE PLACE DECIMAL, C99 4/16		
ANGLE 31°		
DATE	DR.	CHK.
5-25-11	J.R.	M.T.S.
© ALL RIGHTS RESERVED		CERTAINTEED
MACHINE WORKS		
DIVISION		
DRAWING NO. SE HOPPER-A		

TO SHREDDER HOUSING

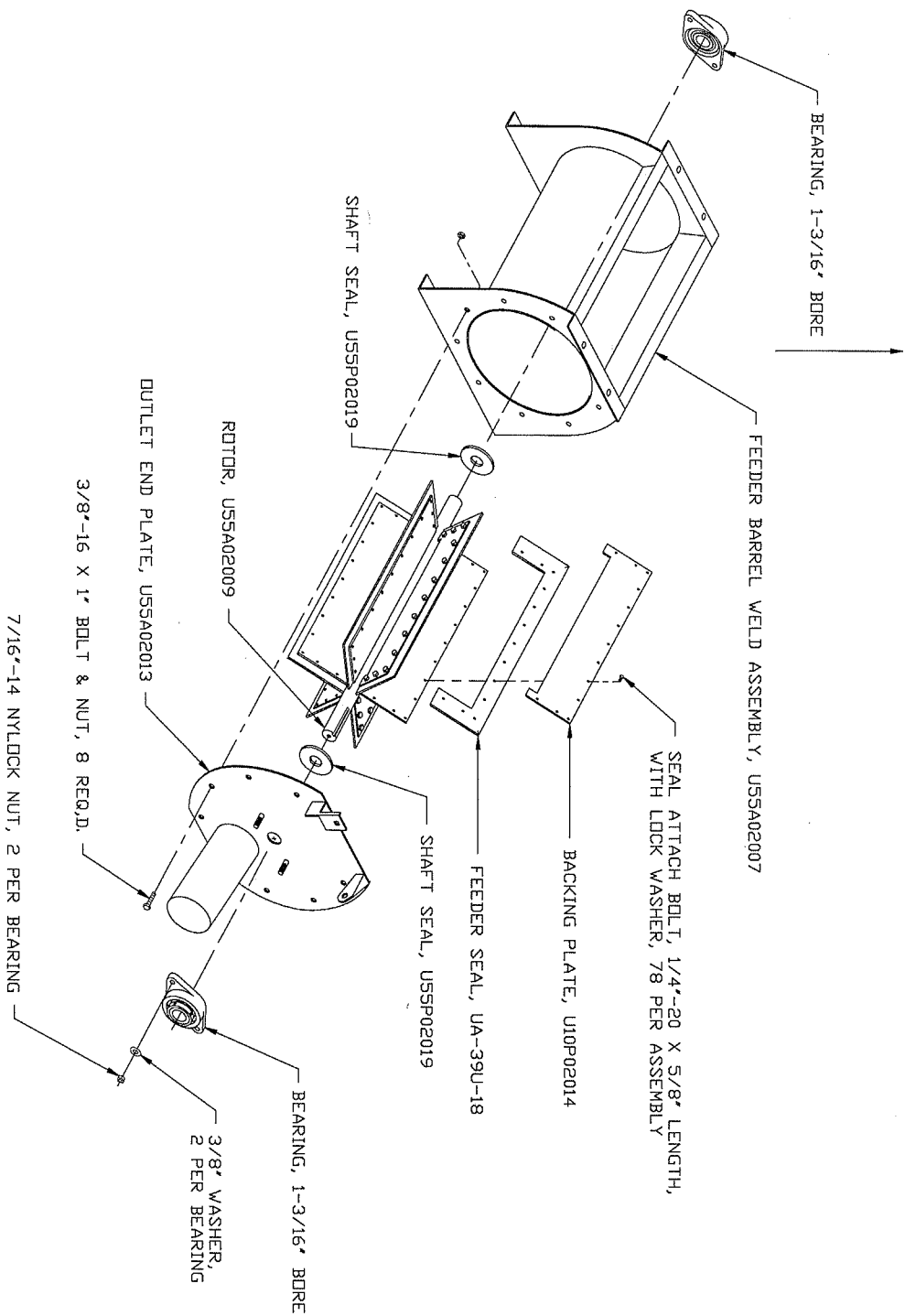

REF.	VAS	CHANGED TO	EFF.
	RECORD	OF CHANGES	

TITLE	TITLE	DATE
VOLU-MATIC SE	VOLU-MATIC SE	3/83
AIRLOCK ASSEMBLY	AIRLOCK ASSEMBLY	3/83
NOTED	NOTED	
© ALL RIGHTS RESERVED <b>CERTAINTEED</b> <b>MACHINE WORKS</b> 1001 W. W. WALKER BLVD. TAMPA, FLORIDA 33604		

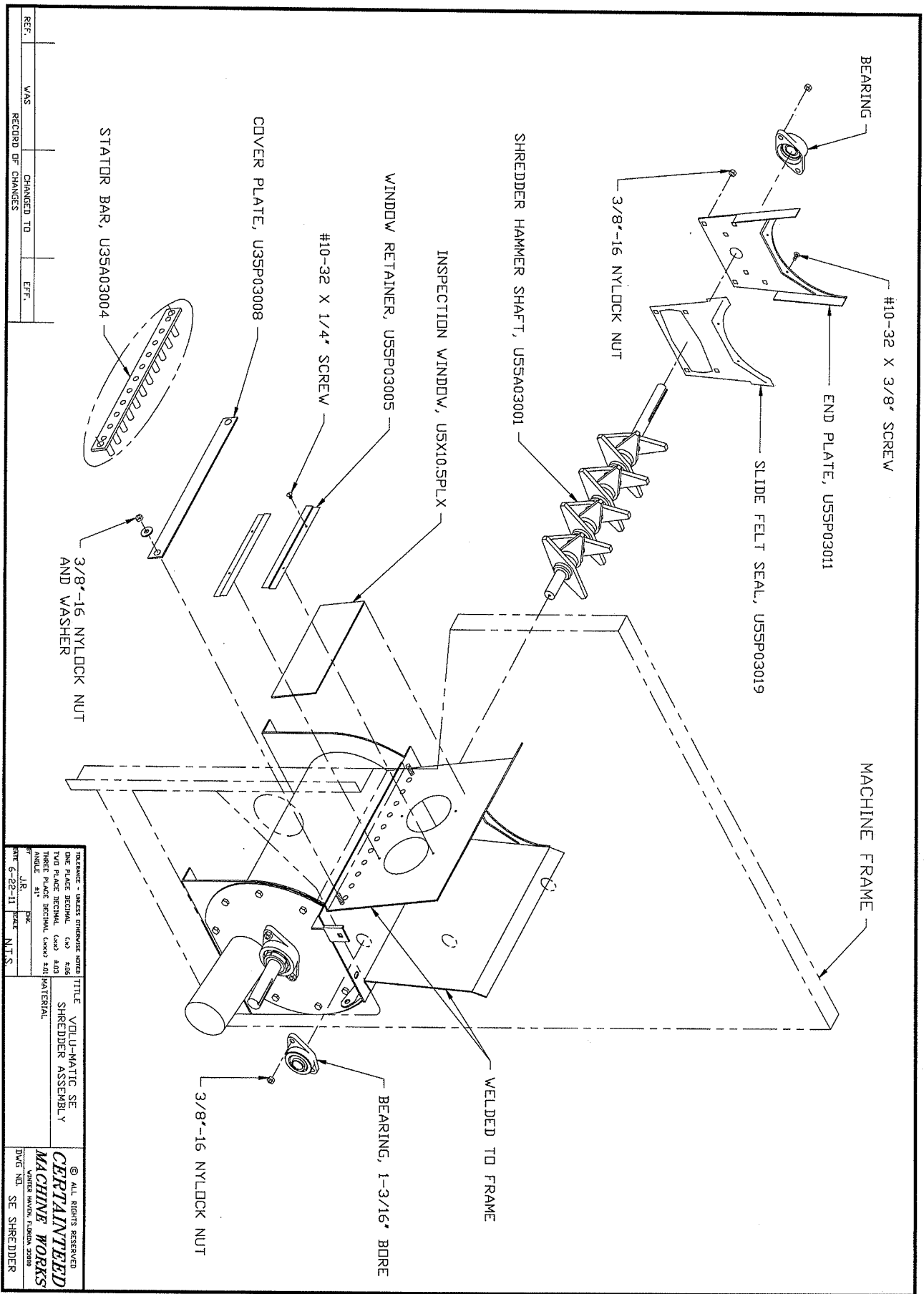

REV.	DATE	BY	CHKD.	DESCRIPTION

REVISIONS: TRACKS EMPLOYEE CODES ONE PLACE DECIMAL TWO PLACE DECIMAL THREE PLACE DECIMAL ANGLE DIM.	TITLE VOLU-MATIC SE SHREDDER ASSEMBLY MATERIAL	© ALL RIGHTS RESERVED <b>CERTAINTEED</b> MACHINE WORKS WINTER HAVEN, FLORIDA 33880
--	---	---

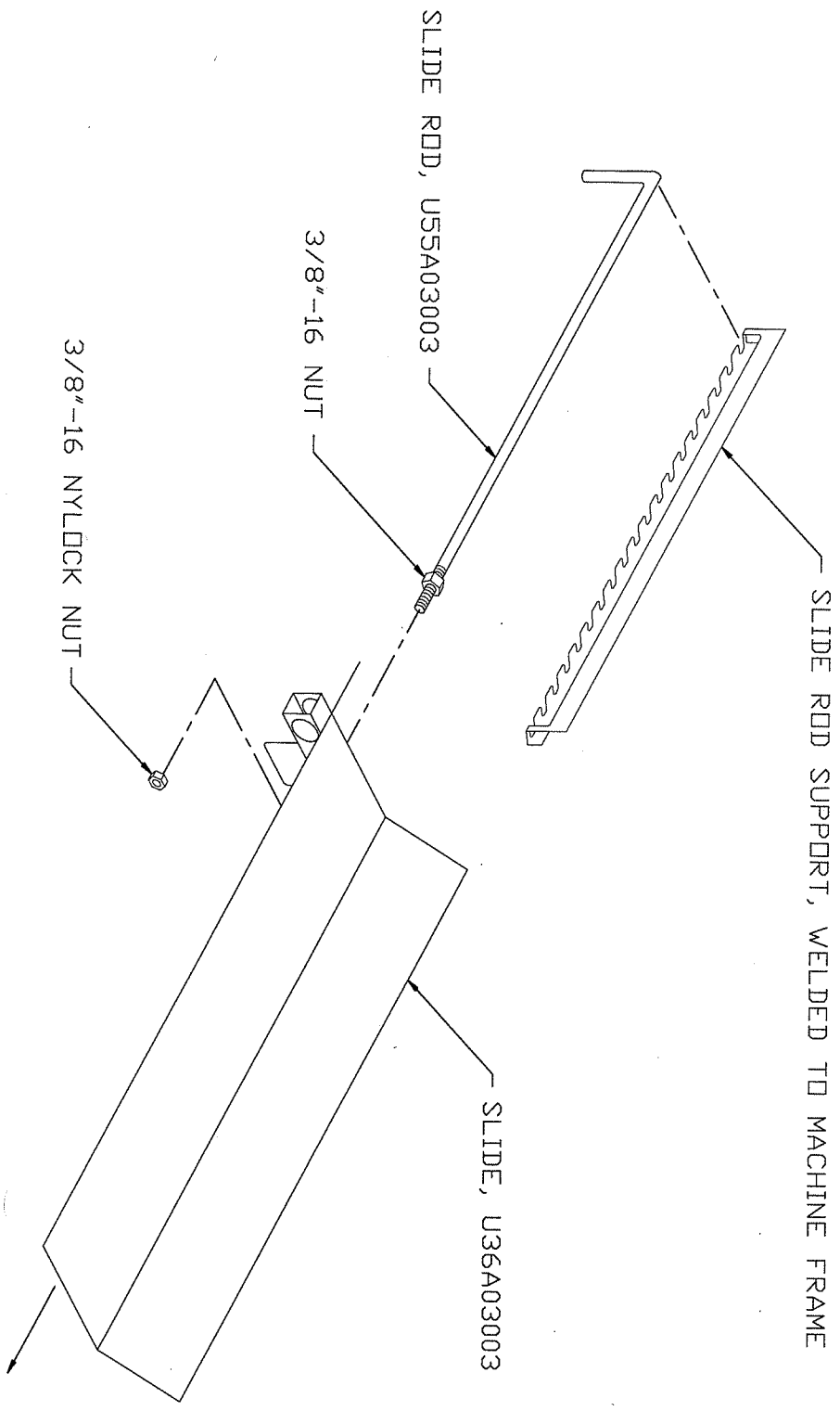

TO SHREDDER HOUSING

REF.			
VAS	RECORD OF CHANGES	CHANGED TO	EFF.

REVISED - UNLESS OTHERWISE NOTED	TITLE	DATE
ONE PLACE DECIMAL, CSD 440	VELU-MATIC SE	
THREE PLACE DECIMAL, CSD 440	SLIDE ASSEMBLY	
ANGLE 31°	MATERIAL	
J.R.	DATE	
6-24-11	SCALE	N.T.S.
© ALL RIGHTS RESERVED <b>CERTAINTEED</b> <b>MACHINE WORKS</b> <small>UNION LAVERN, FLORIDA 32680</small>		DWG NO. SE SLIDE

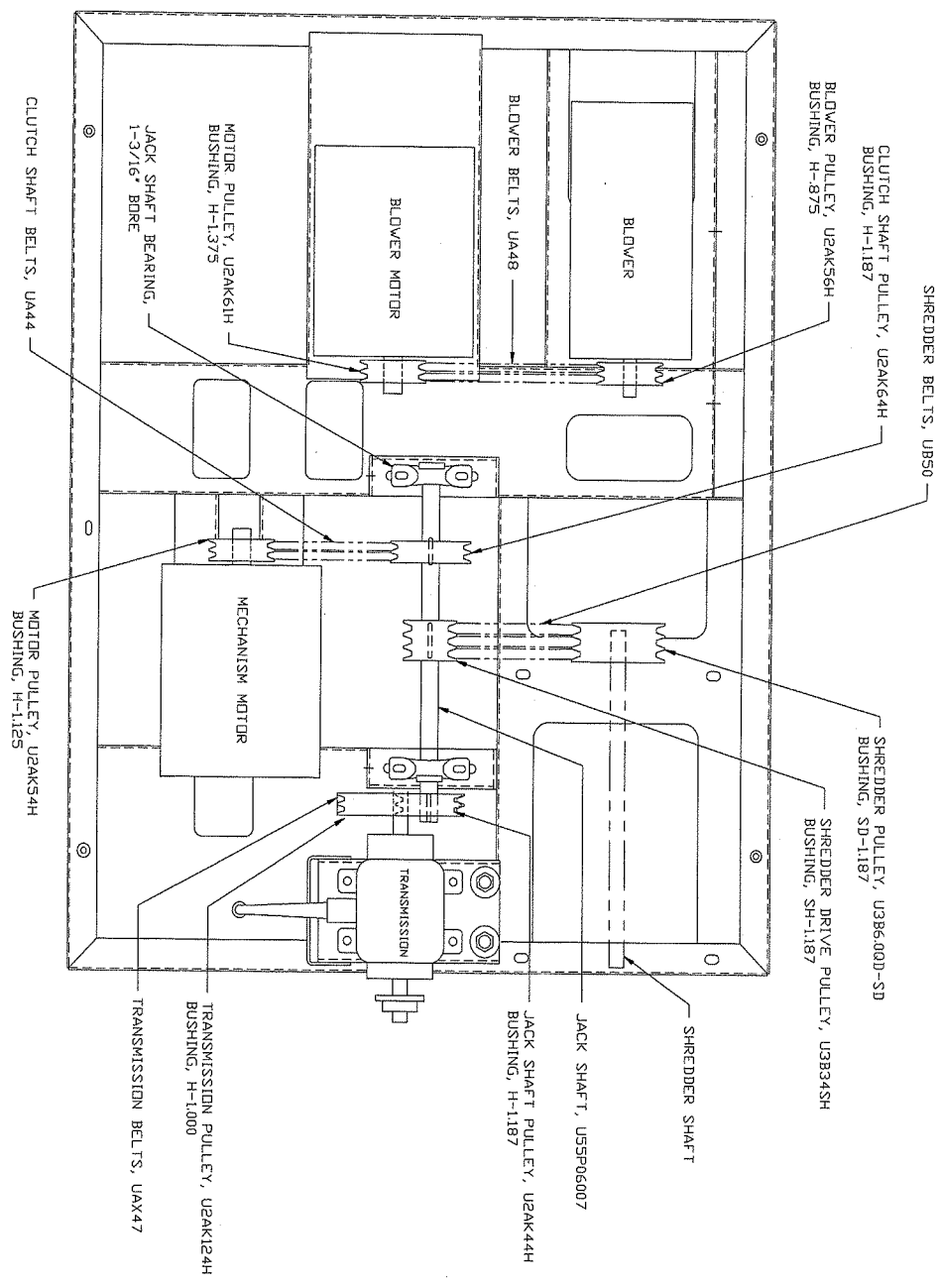

REF.	VAS	RECORD	CHANGED TO	EFF.

TOLERANCE - UNLESS OTHERWISE NOTED ONE PLACE DECIMAL .0125 TWO PLACE DECIMAL .0031 THREE PLACE DECIMAL .0009 FINISH - UNLESS OTHERWISE NOTED UNLESS OTHERWISE SPECIFIED ALL DIMENSIONS ARE IN INCHES UNLESS OTHERWISE SPECIFIED	TITLE VOLU-MATIC SE ELECTRIC DRIVE TRAIN MATERIAL NOTED	© ALL RIGHTS RESERVED <b>CERTAINTEED</b> <b>MACHINE WORKS</b> 10000 W. UNIVERSITY BLVD. SUITE 100 TAMPA, FLORIDA 33613
--	---	---



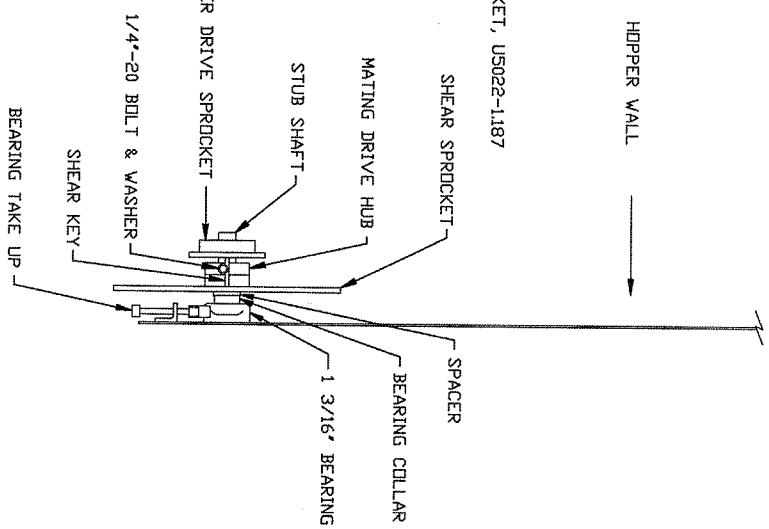
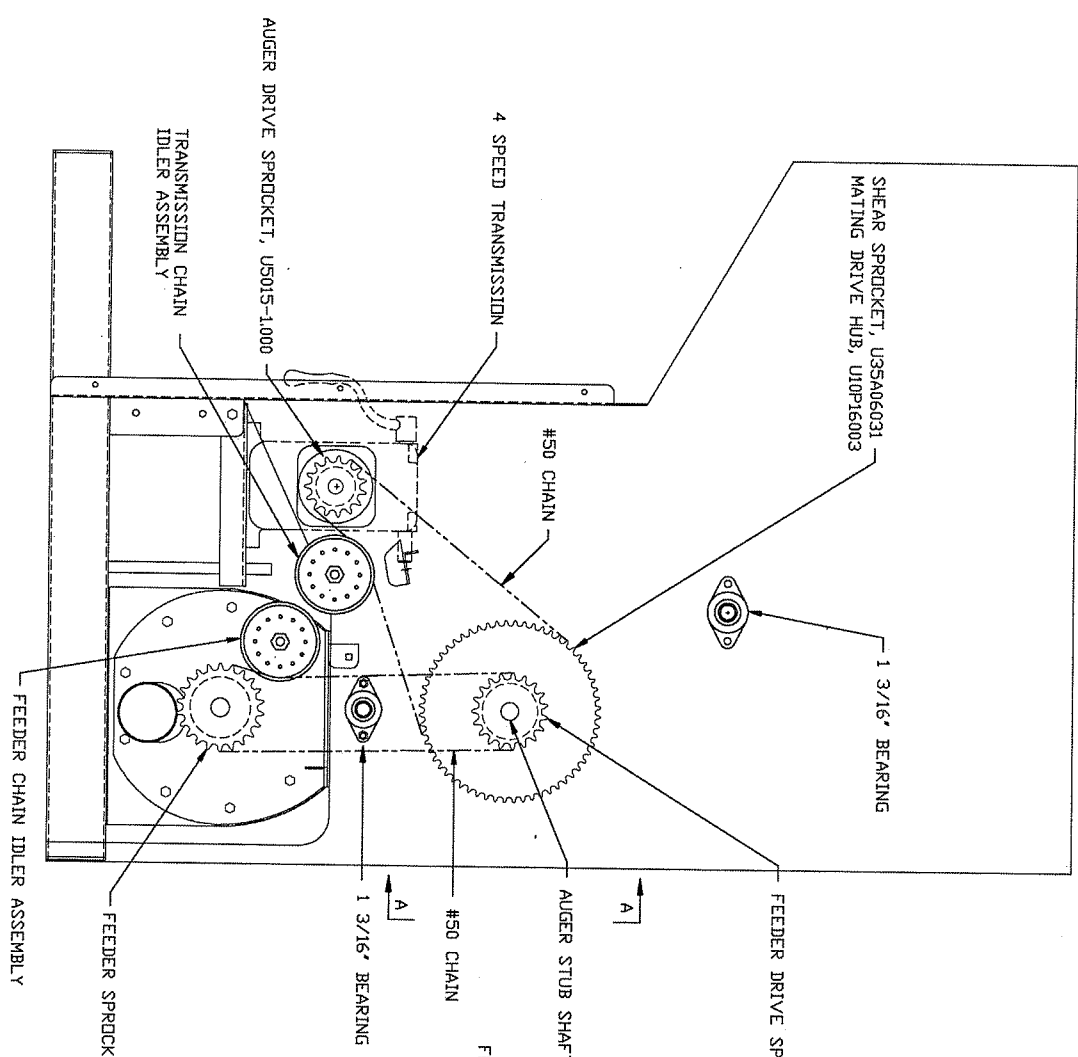

NOTE: MAKE SURE TO SET SPACER AND SHEAR SPROCKET FLUSH TO BEARING COLLAR, SET SHEAR HUB FLUSH TO SHEAR SPROCKET, INSERT SHEAR KEY AND LOCK DRIVE HUB TO SHAFT.

REF.	VAS	CHANGED TO	EFF.
		RECORD OF CHANGES	

DESIGNED BY	J.R.	DATE	5-19-11
CHECKED BY	M.T.S.		
TITLE	SE CHAIN DRIVE RIGHT SIDE		
DRAWN BY	CERTAINTEED MACHINE WORKS		
SCALE	AS SHOWN		
MATERIAL	SEE DRAWING		
FINISH	SEE DRAWING		
QUANTITY	SEE DRAWING		
REVISIONS	SEE DRAWING		

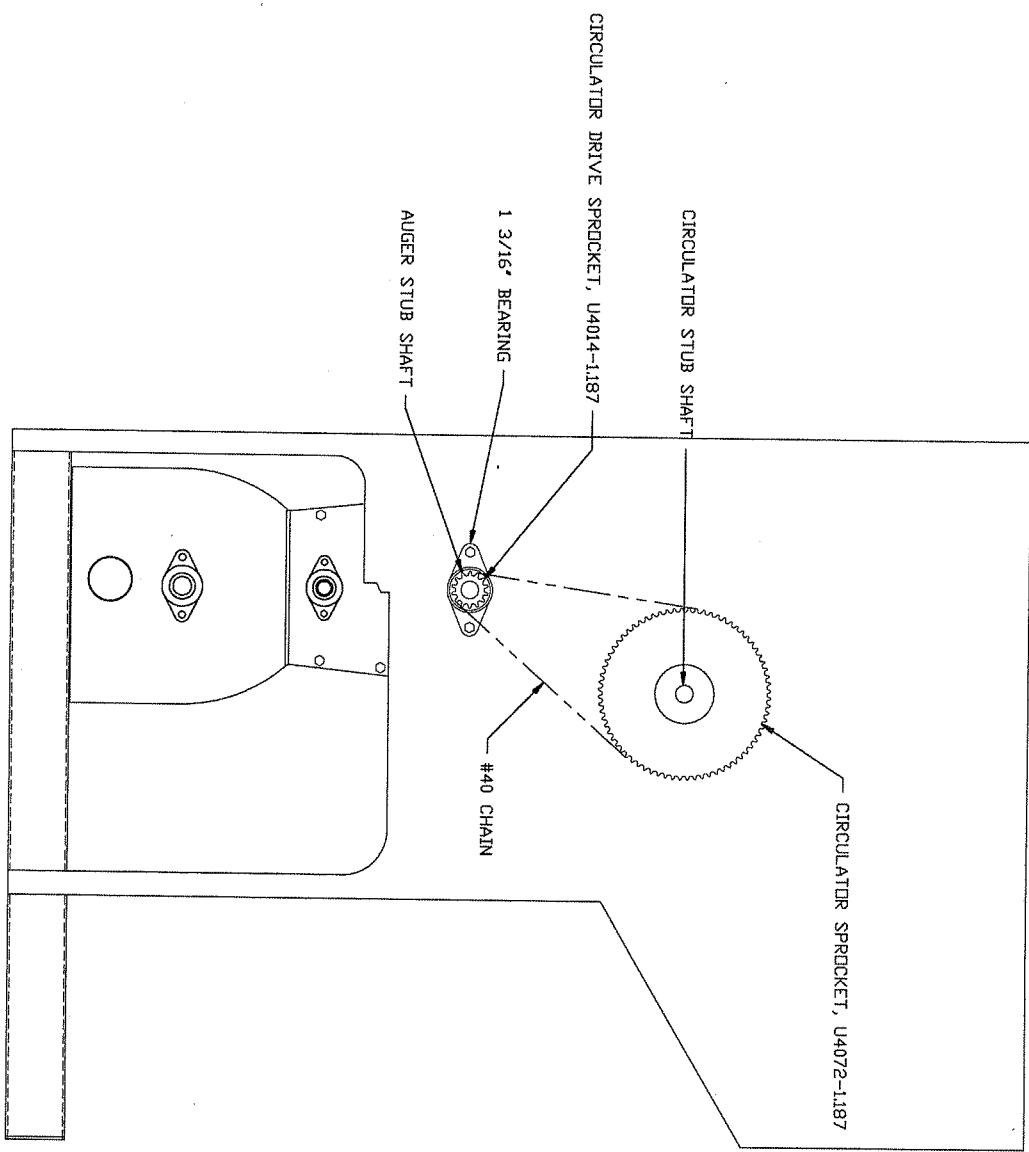

REF.			
	WAS	RECORDED	OR CHANGED TO
			EFF.

TOLERANCE - UNLESS OTHERWISE NOTED		TITLE	
DIG. THREE DECIMAL	0.01	SE CHAIN DRIVE	
TWO PLACE DECIMAL	0.05	LEFT SIDE	
ONE PLACE DECIMAL	0.50		
ANGLES	30°	MATERIAL	
DRG. NO.	J.R.	DATE	5-19-41
SCALE	1" = 1"	NTS	
© ALL RIGHTS RESERVED <b>CERTAINTEED</b> <b>MACHINE WORKS</b> 10000 W. WASHINGTON ST. WILSON, ILLINOIS 60190		SE LEFT SIDE CHAIN DRIVE-A DRG. NO.	

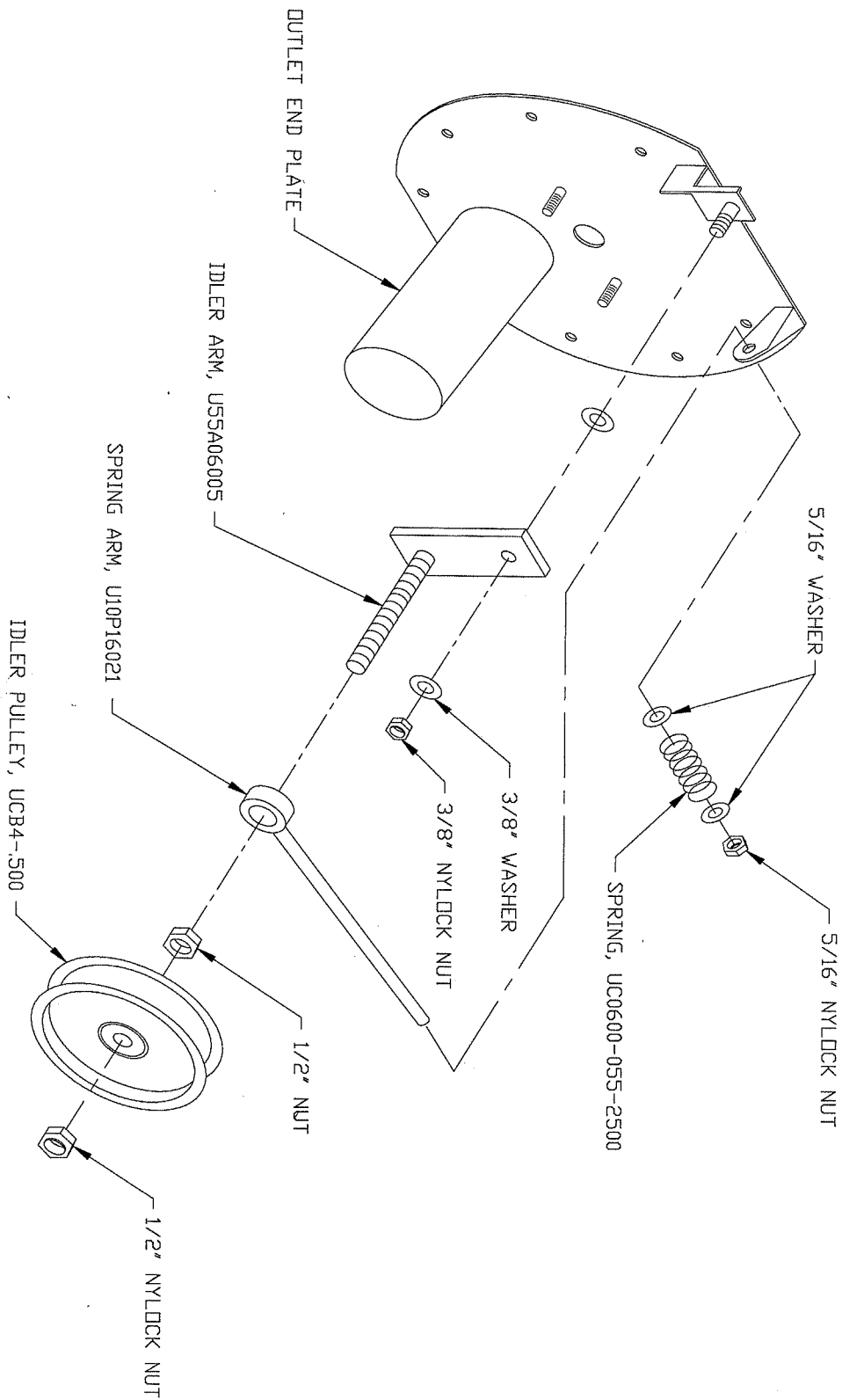

REF.	WAS	CHANGED TO	EFF.
	RECORD OF CHANGES		
TOLERANCE - UNLESS OTHERWISE NOTED ONE PLACE DECIMAL (x) ±.06 TWO PLACE DECIMAL (xx) ±.03 THREE PLACE DECIMAL (xxx) ±.01 ANGLE ±1°			
BY	J.R.	CHK	
DATE	5-27-11	SCALE	N.T.S.
TITLE		CHAIN IDLER ASSEMBLY	
MATERIAL		AUGER TO FEEDER	
DWG NO.		MACHINE WORKS	
SE FEEDER CHAIN IDLER ASSY		© ALL RIGHTS RESERVED	
		WINTER HAVEN, FLORIDA 33980	

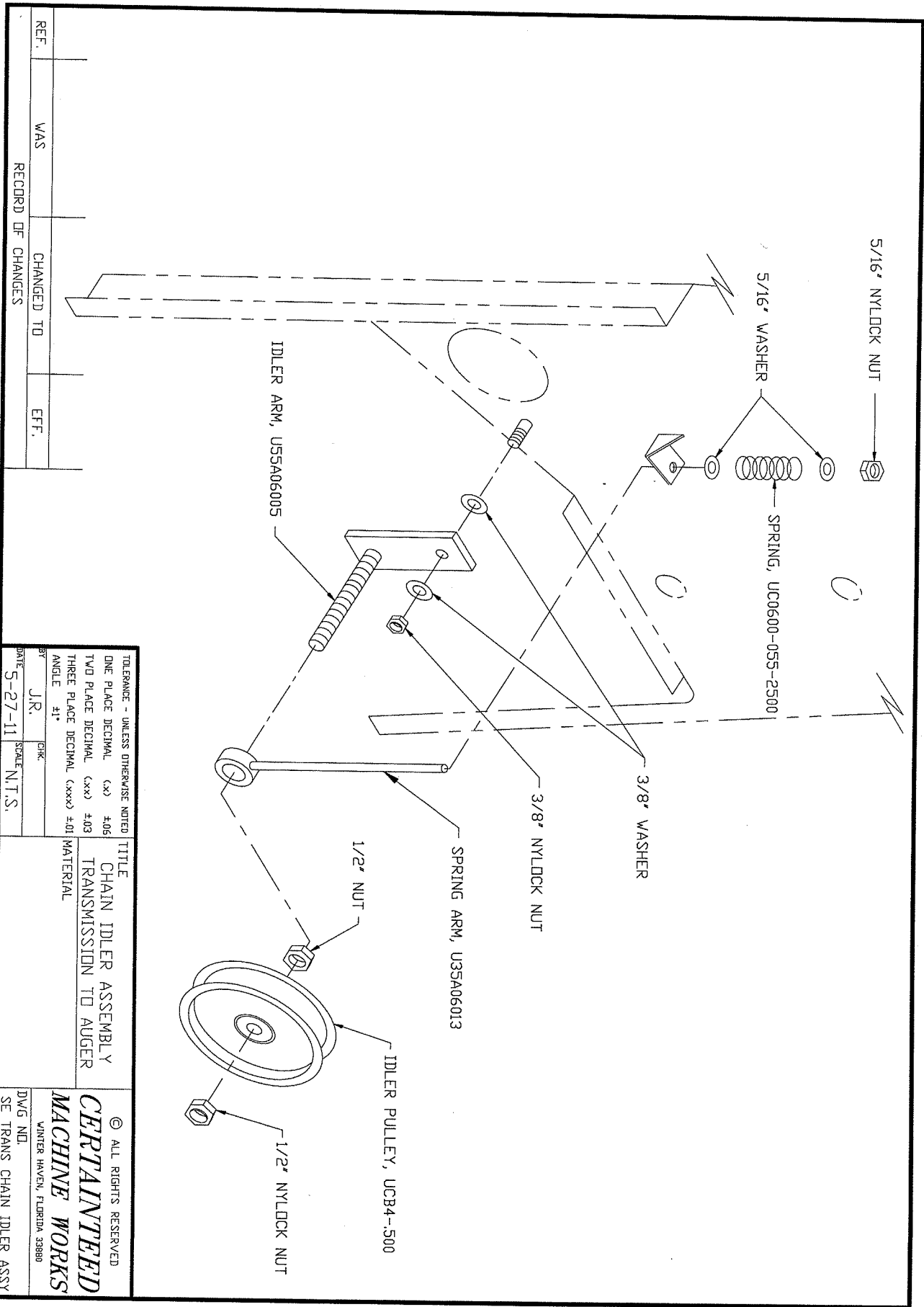

TOLERANCE - UNLESS OTHERWISE NOTED		TITLE	
ONE PLACE DECIMAL (x)	±.06	CHAIN IDLER ASSEMBLY	
TWO PLACE DECIMAL (xx)	±.03	TRANSMISSION TO AUGER	
THREE PLACE DECIMAL (xxx)	±.01	MATERIAL	
ANGLE #1°			
BY J.R.	CHK		
DATE 5-27-11	SCALE N.T.S.		
© ALL RIGHTS RESERVED <b>CERTAINTEED</b> <b>MACHINE WORKS</b> WINTER HAVEN, FLORIDA 33980		DWG NO. SE. TRANS CHAIN IDLER ASSY	

REF.	WAS	CHANGED TO	EFF.
		RECORD OF CHANGES	

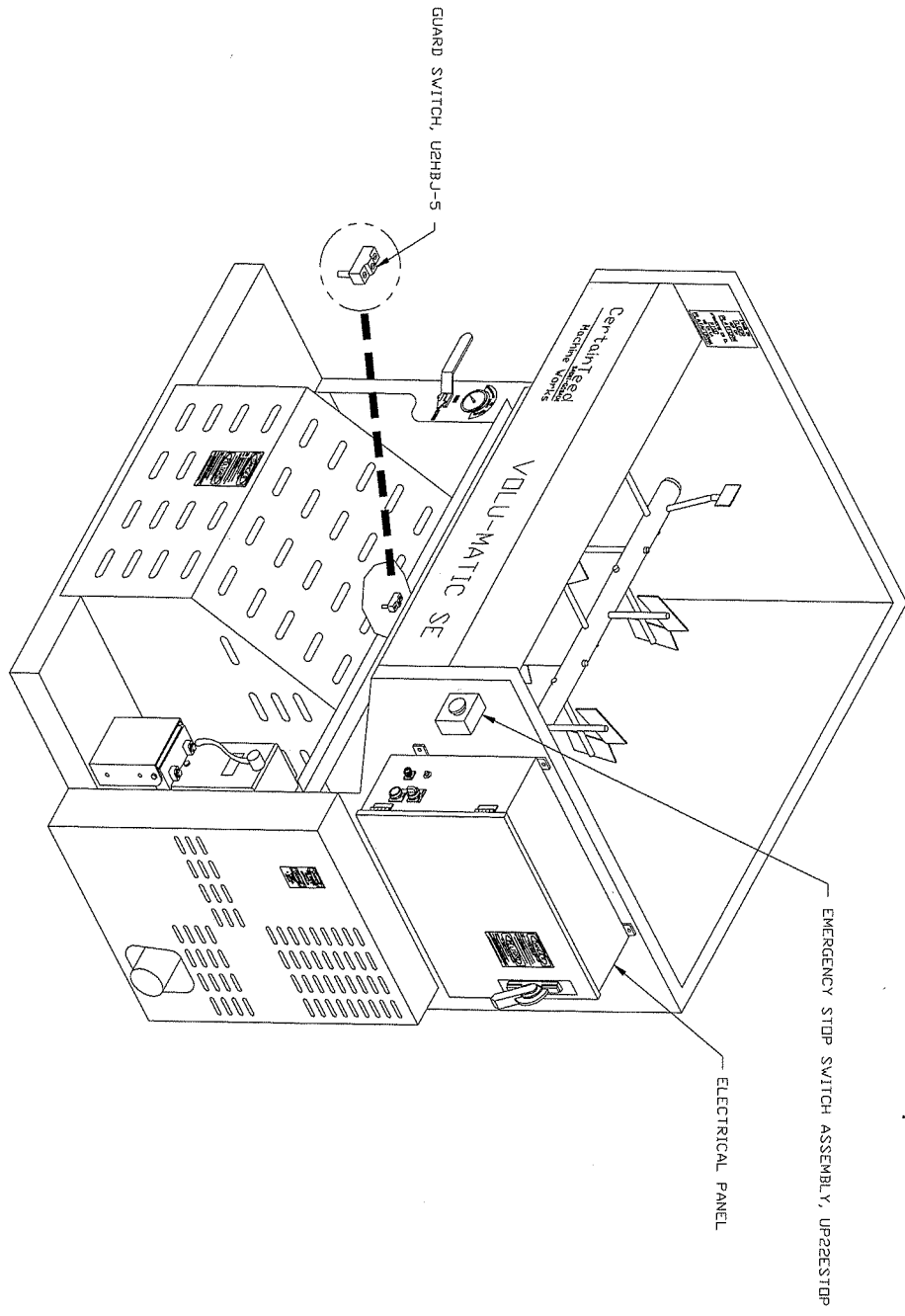

REF.			
VAS	RECORD OF CHANGES	CHANGED TO	EFF.

TOLERANCE - UNLESS OTHERWISE NOTED		TITLE	
ONE PLACE DECIMAL, (X) 4.00		VDU-MATIC SE MACHINE	
TWO PLACE DECIMAL, (XX) 4.00		MATERIAL	
THREE PLACE DECIMAL, (XXX) 4.00		SE ELECTRICAL PANEL	
APPROVED BY: J.R. [Signature]	DATE: 10-15-12	N.T.S.	
© ALL RIGHTS RESERVED		CERTAINTEED MACHINE WORKS	
DWG NO. SE ELECTRICAL PANEL		UNIVERS MANUFACTURING, TAMPA, FLORIDA 33601	

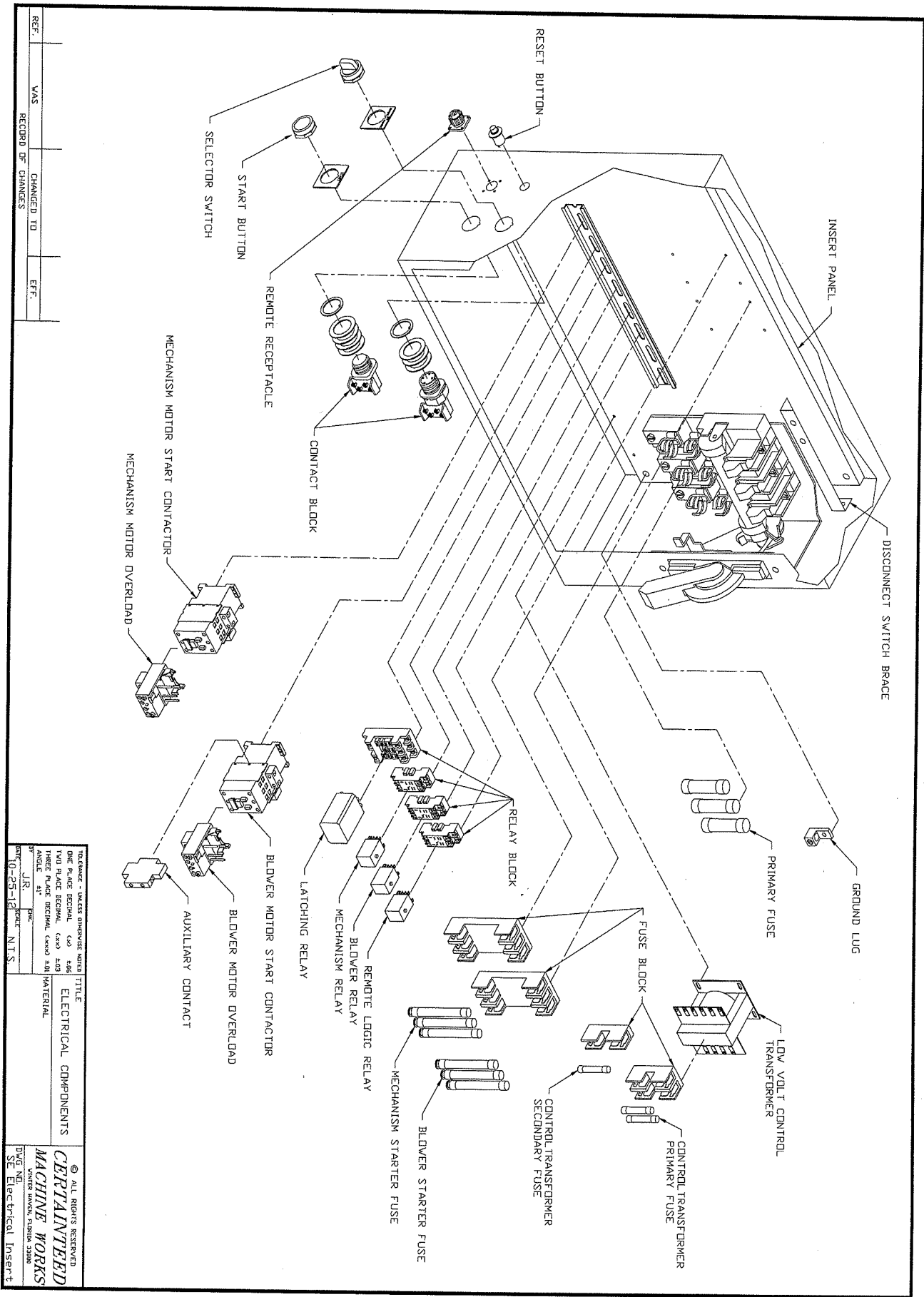

REF.	VAS	RECORD OF CHANGES	CHANGED TO	EFF.
------	-----	-------------------	------------	------

TOLERANCE - UNLESS OTHERWISE NOTED ONE PLACE DECIMAL (x.0) ±.05 TWO PLACE DECIMAL (x.00) ±.025 THREE PLACE DECIMAL (x.000) ±.010 FINISH - UNLESS OTHERWISE NOTED NONE DIM. UNLESS OTHERWISE NOTED NONE DIM. UNLESS OTHERWISE NOTED NONE DIM. UNLESS OTHERWISE NOTED NONE	TITLE ELECTRICAL COMPONENTS MATERIAL NTS	© ALL RIGHTS RESERVED <b>CERTAINTEED</b> <b>MACHINE WORKS</b> DIV. OF SE Electrical Insert
---	---	--

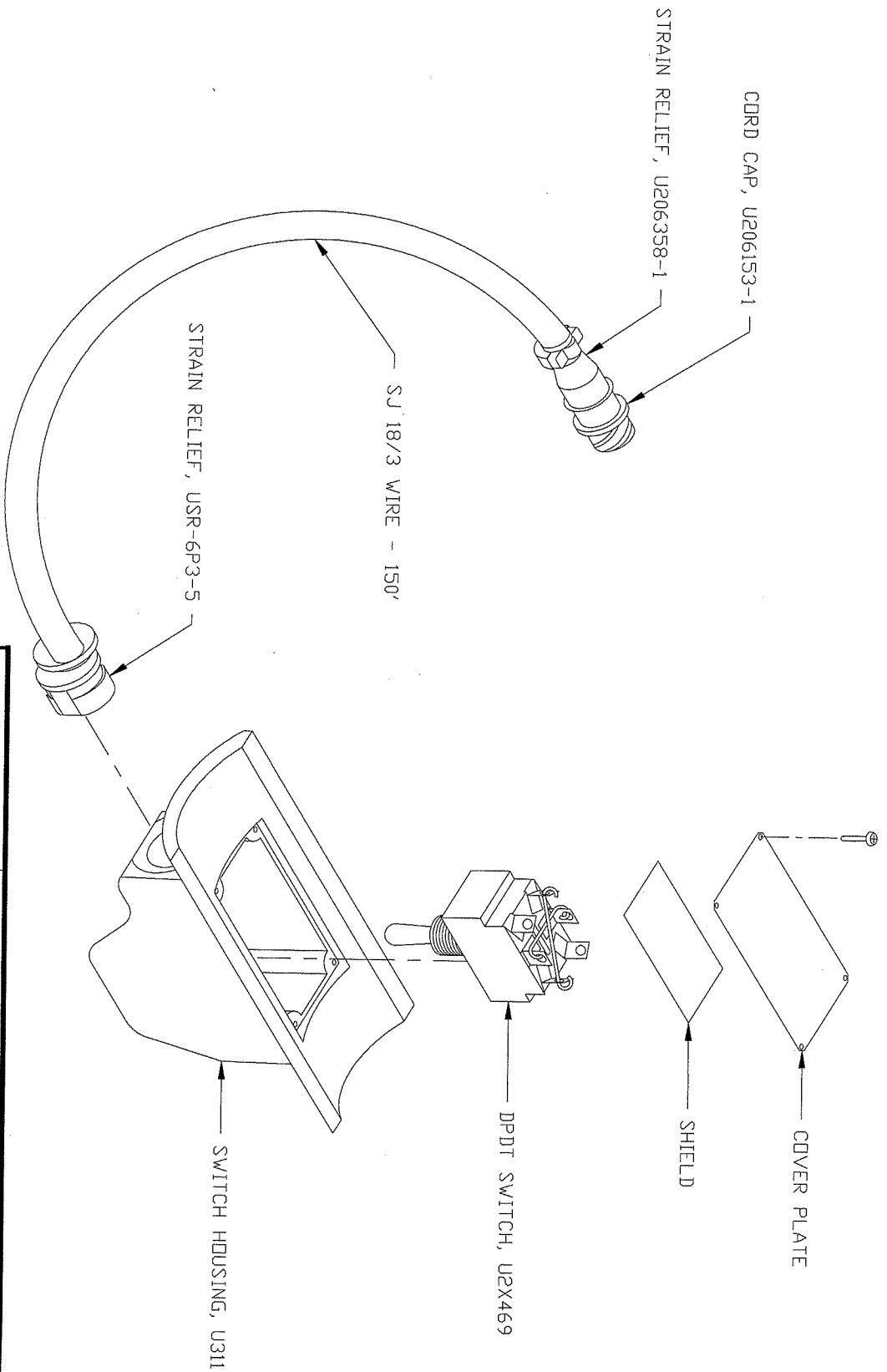

REF.	WAS	CHANGED TO	EFF.
	RECORD OF CHANGES		
TOLERANCE - UNLESS OTHERWISE NOTED ONE PLACE DECIMAL (x) ±.06 TWO PLACE DECIMAL (xx) ±.03 THREE PLACE DECIMAL (xxx) ±.01 ANGLE ±1°			
BY: J.R.	CHK:	DATE: 10-22-12	SCALE:
TITLE		MATERIAL	
REMOTE CORD ASSEMBLY			
© ALL RIGHTS RESERVED <b>CERTAINTEED</b> <b>MACHINE WORKS</b> WINTER HAVEN, FLORIDA 33880		ELVMSERemoteCord.dwg	

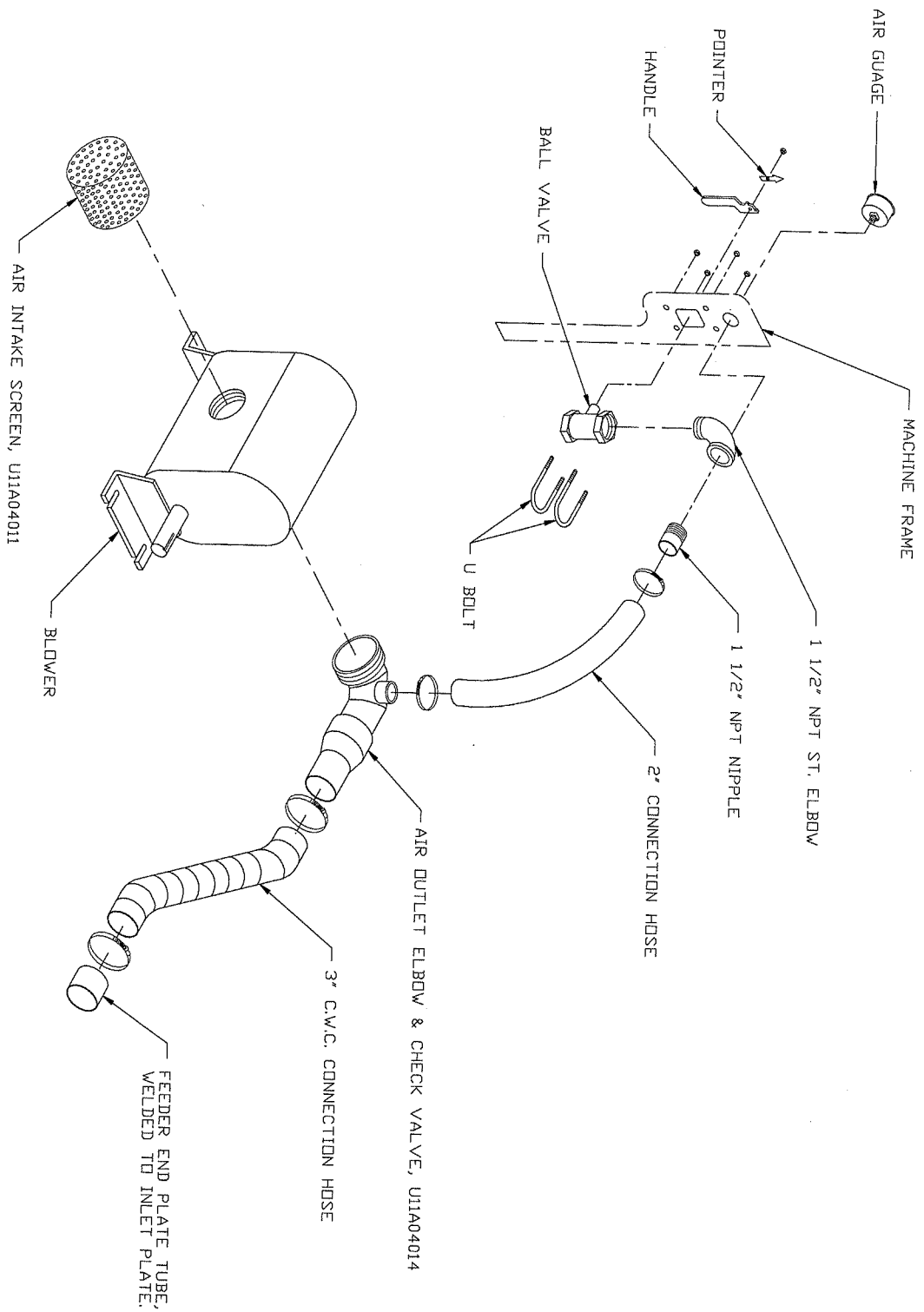

REF.			
VAS	CHANGED TO		
	RECORD OF CHANGES	EFF.	

DESIGNED - BATES DREWRYE NOTED	TITLE	© ALL RIGHTS RESERVED
ONE PLACE DECIMAL, (3) 4.03	AIR STREAM	<b>CERTAINTEED</b>
TWO PLACE DECIMAL, (3) 4.03	VOLU-MATIC SE	<b>MACHINE WORKS</b>
THREE PLACE DECIMAL, (3) 4.03	MATERIAL	MADE IN THE U.S.A.
DATE 2/28/51	NOTED	SE AIR STREAM
BY J.R.		
CHK 5-17-51	NTS	



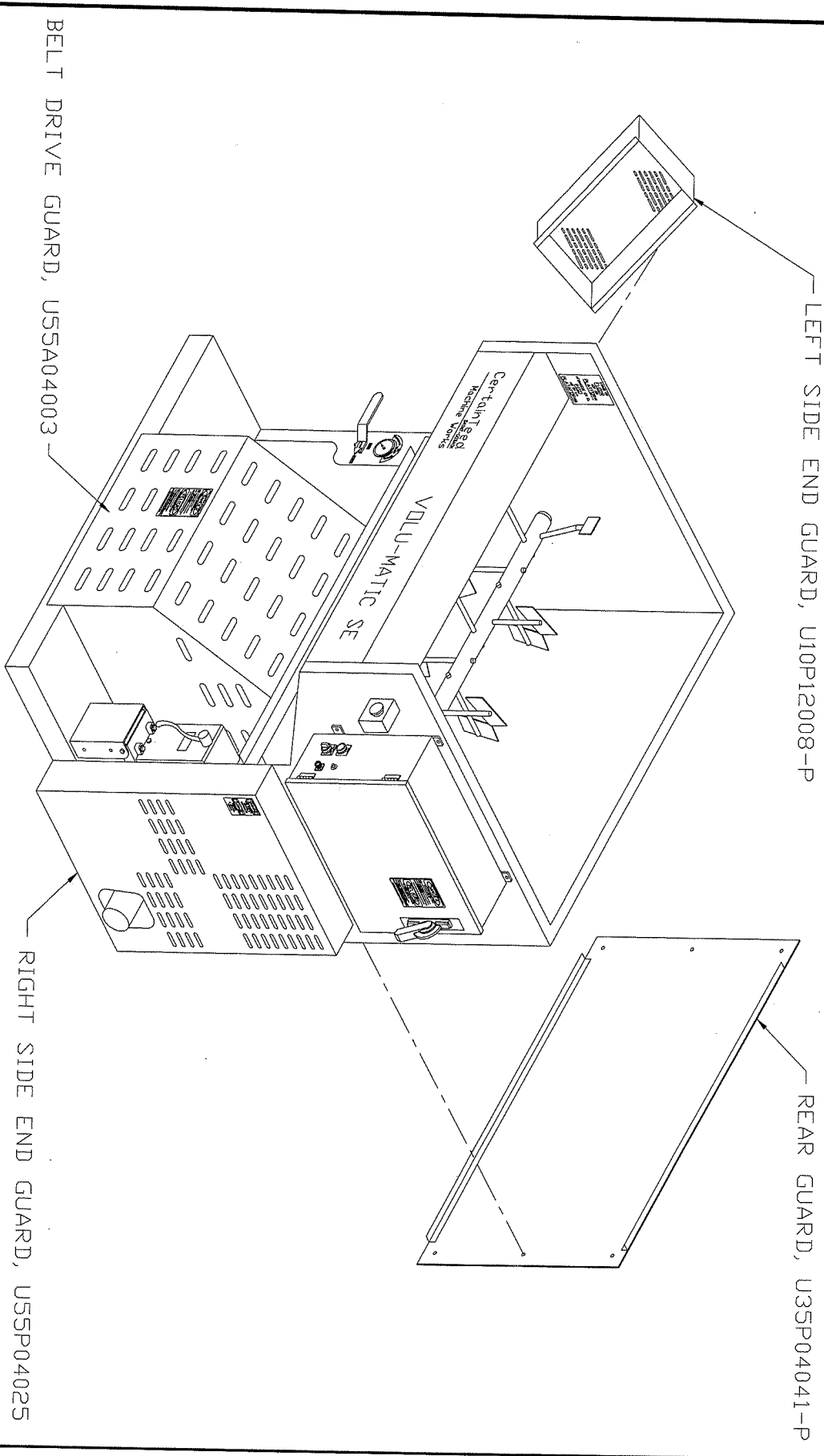

LEFT SIDE END GUARD, U10P12008-P

REAR GUARD, U35P04041-P

BELT DRIVE GUARD, U55A04003

RIGHT SIDE END GUARD, U55P04025

REF.	VAS	RECORD	OR	CHANGED	TO	EFF.

TELEPHONE - UNLESS OTHERWISE NOTED ONE PLACE DECIMAL (x) 426 TWO PLACE DECIMAL (xx) 423 THREE PLACE DECIMAL (xxx) 401		TITLE VDU-MATIC SE GUARDS	
BY: J.R. P.M. DATE: 10-22-1978		MATERIAL SE GUARDS-ELECTRIC	
© ALL RIGHTS RESERVED <b>CERTAINTEED</b> <b>MACHINE WORKS</b> <small>INCORPORATED - TORONTO, CANADA</small>			

**CERTAINTEED MACHINE WORKS BLOWING EQUIPMENT**  
**LIMITED TWO-YEAR WARRANTY**

CertainTeed Machine Works (the Company) warrants to each original purchaser (the Buyer) of its blowing equipment that such products will be free of manufacturing defects for a period of two years from the date of shipment to the Buyer, except that no warranty is made with respect to:

1. Components or accessories manufactured and warranted by others. Warranties for component parts, including but not limited to the engine, blower, gearbox, and transmission, if furnished by the manufacturer of the component, are on file at the Company's main office and copies will be furnished with the blowing equipment when sold. In no event shall the Company provide service on any such component.
2. Any defect caused by alteration performed without the express written authorization of the Company.
3. Repairs made or attempted or adjustments undertaken by unauthorized persons.
4. Any machine that has not been operated and/or maintained in accordance with normal industry practice and the written recommendations of the Company, such as a machine operated with an improperly sized, worn or damaged hose.
5. Damage or breakage due to carelessness, accidents, or improper use.
6. The results of any application or use of the blowing equipment.

This limited warranty does not extend to component parts that need to be replaced on a regular basis due to normal wear and usage, including but not limited to seals, feeder, shredder, auger, fuses, switches, clutches, hoses, shaft seals, chains, belts, sprockets, pulleys, bearings, cables, and batteries.

The Company's obligation under this warranty is limited to repairing or replacing (at its option) any part that is determined by the Company to have a manufacturing defect. The Company or an authorized repair facility will provide any required parts and labor to the Buyer. If the equipment must be returned to the Company for repair, all transportation costs shall be the Buyer's responsibility. The Buyer must obtain a Return Material Authorization (RMA) number from the Company before returning the equipment for repair.

THIS LIMITED WARRANTY IS EXPRESSLY IN LIEU OF ANY OTHER GUARANTEES AND/OR WARRANTIES, ORAL OR WRITTEN, EXPRESSED OR IMPLIED, INCLUDING, WITHOUT LIMITATION, THE IMPLIED WARRANTY OF MERCHANTABILITY AND THE IMPLIED WARRANTY OF FITNESS FOR A PARTICULAR PURPOSE. THE COMPANY SHALL NOT UNDER ANY CIRCUMSTANCES BE LIABLE FOR ANY SPECIAL, INDIRECT, INCIDENTAL OR CONSEQUENTIAL DAMAGES OF ANY KIND, OR ECONOMIC LOSS, INCLUDING DAMAGES TO ANY BUILDING OR ITS CONTENTS, OR INJURY TO ANY PERSONS THEREIN, LOSS OF PROFITS, REVENUE, OR LOSS OF EQUIPMENT USE, EVEN IF THE COMPANY HAS BEEN ADVISED OF THE POSSIBILITY OF SUCH DAMAGES OR LOSS, OR FOR ANY CLAIM AGAINST THE BUYER BY ANY OTHER PARTY.

This warranty is not transferable.

Any claimed defect for which the Company does not receive notice within the two-year warranty period is not covered by this warranty.

**CertainTeed**  
SAINT-GOBAIN

**Machine Works**

101 Hatfield Rd, Winter Haven, FL 33880

**800-237-7841**

[www.certainteedmachineworks.com](http://www.certainteedmachineworks.com)

© 2012 CertainTeed Corporation