

NOTE: Proper edge flashing restoration is condition dependent; CertainTeed offers multiple details for use as required based on the condition of the existing flashing; multiple details could be implemented on a single roof. This detail is applicable to portions of the preexisting edge flashing that is left in place but with points of weak adhesion along the edge. If the edge flashing is poorly adhered such that metal can be exposed, it should be cut back, see CTL-SC-01B or CTL-SC-01C.

Edge Metal

Clean exposed metal, completely removing any rust; preexisting edge metal typically does not require primer for adhesion though any rusted areas shall be primed with SMARTCOAT 210 Universal Primer.

Mastic/Reinforced Mastic (3-Course)

Apply SMARTCOAT 300 Acrylic Mastic or 350 Silicone Mastic with a brush, trowel or gloved hand at a maximum thickness of 1/8" for 300 and 1/4" for 350, up and over the edge metal extending 2" onto the façade surface. Immediately embed SMARTFAB 500 Polyester Reinforcement, minimum 4" width, into wet mastic followed by a second coat of mastic at prescribed thickness to encapsulate edges and surface of polyester. Ensure the polyester is evenly covered and the edges of the detail are properly feathered.

Liquid-Applied Membrane/Coating, Field

Once mastic is cured, apply coating in accordance with specified SMARTCOAT application.

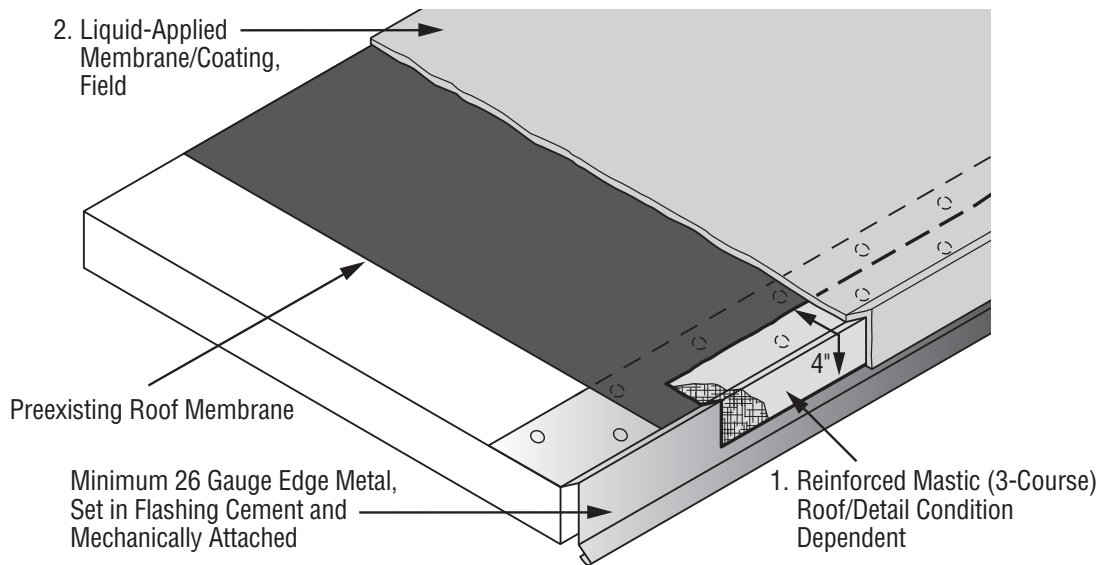

NOT DRAWN TO SCALE

NOTE: Never repair or coat-over silicone-based mastic or coating with anything other than a compatible silicone-based product; acrylic materials will not bond to silicone. If new metal is installed, clean and remove any oil or residue that could inhibit adhesion.

NOTE: When portions of the detail have undergone previous repairs and if the repairs have been made with compatible materials and are sound, repair can be left in place and reinforced mastic (3-course) applied atop; if the repair was made with incompatible materials, is failing or has potential for high movement, remove these materials and proceed with reinforced mastic (3-course/5-course as appropriate).