

NO-COAT PRO

Operating Instructions

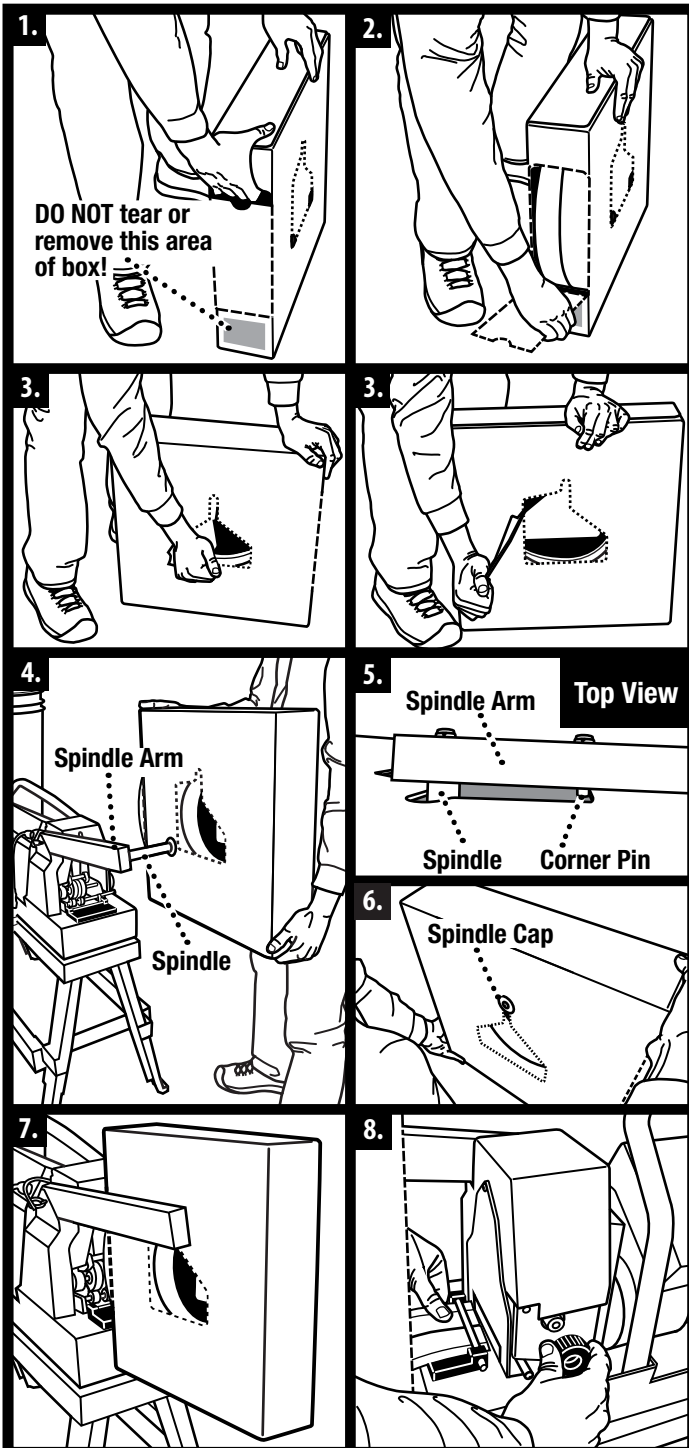

TO LOAD NO-COAT PRO CORNER INTO THE NO-COAT PRO MACHINE:

1. Push in perforated section above finger hole.
2. Tear out perforated large end panel and remove.
3. Using finger holes, remove perforated panels on both sides of the box.
4. Lift box with perforated end panel facing machine, and mount over spindle.
5. Box should fit snugly against spindle arm, resting on the spindle and corner pin (as shown in #7).
6. On opposite box side, make sure box sits on spindle and is secured in place by spindle cap.
8. Pull end of NO-COAT PRO Corner out of box between guides.
9. Feed NO-COAT PRO Corner through open slot into feed rollers using the feed knob. Make sure center groove in product lines up with centering roller. Turn feed knob until product stops against inside cutter blade.
10. To remove or adjust position of NO-COAT PRO Corner, push down on feed release lever.

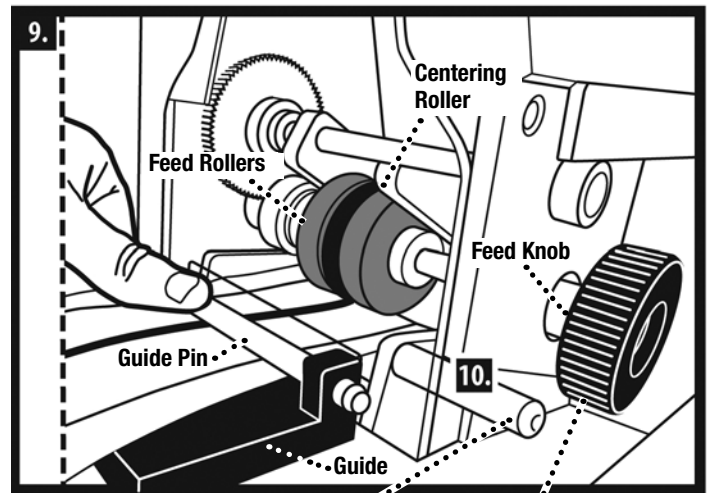

Feed Release Lever

Turn Feed Knob counter-clockwise only!

SETTING FOR OUTSIDE OR INSIDE CORNER

For an outside corner:

1. Rotate the folder handle away from you until the folder handle rests against the stop pin in the OUT position.
2. Locate the hopper with the tapered feet in the far set of locating holes.

For an inside corner:

1. Rotate the folder handle toward you until the folder handle rests against the stop pin in the IN position.
2. Locate the hopper with the tapered feet in the near set of locating holes.

Language

To set the language of the display to English or Spanish:

1. Press MENU and select "2 - English/Español".
2. Select language.

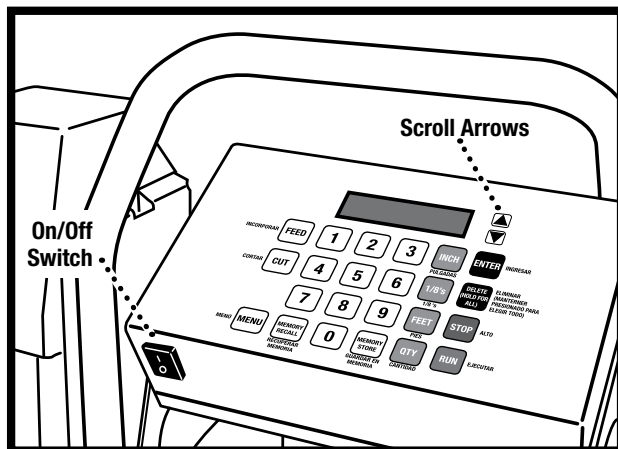
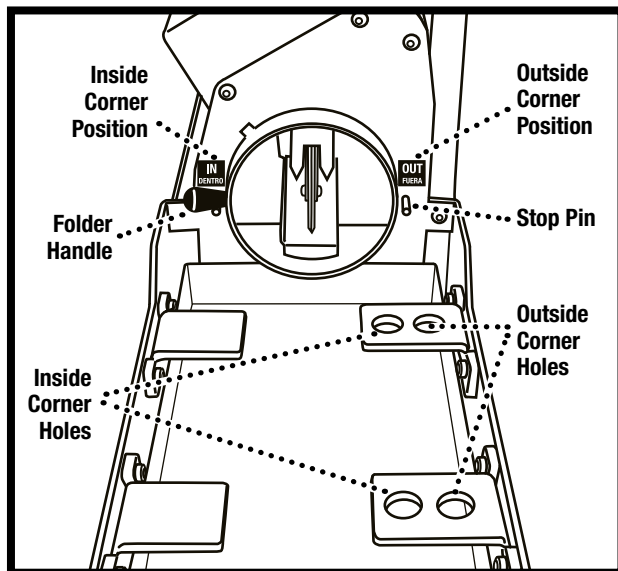

RUNNING CORNERS

Enter "run mode":

1. Make certain the product is loaded properly and the product box is touching the end of the NO-COAT PRO.
2. Make certain the folder and hopper are both set for the desired corner (inside or outside).
3. Press RUN or the remote button to enter "run mode" and dispense the first corner on the list.
4. To pause the corner output, press STOP or the remote button during output - press RUN or the remote button to resume.
5. Press RUN or the remote button to dispense the next corner on the list.

Pulling corners out of the NO-COAT PRO

1. Support the corner as it comes out of the NO-COAT PRO. Wait to pull the corner until you hear the NO-COAT PRO cut the corner - if you pull the corner before the cutter fires, it may cause length errors.
2. After the NO-COAT PRO cuts the corner, be certain to pull the corner from the NO-COAT PRO smoothly and at a consistent speed to ensure optimal joint compound coverage on the corner. Pulling the corner out too rapidly may result in gaps in joint compound coverage. Also, be careful to pull the corner straight out and level, to avoid deforming the corner.
3. Do not run another corner until you have removed the previous corner from the NO-COAT PRO.

Exit "run mode"

1. Press STOP to exit "run mode" in order to edit the corner data, edit the list, recall a stored list, etc.

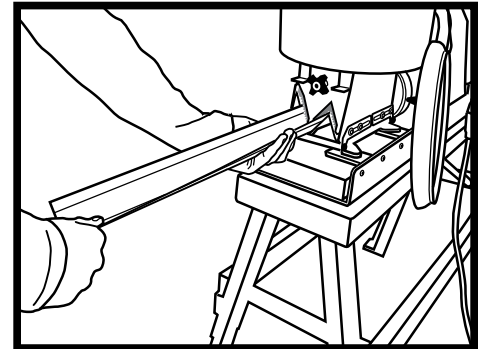

End of roll

In the event that the end of a roll is reached while dispensing a corner the NO-COAT PRO will stop dispensing and not cut.

1. Remove the current corner from the NO-COAT PRO. DO NOT PRESS CUT BEFORE REMOVING THE CORNER - pressing cut before removing the corner may cause a small piece of product to remain in the cutter which may jam the NO-COAT PRO.
2. Press CUT to reset the NO-COAT PRO.
3. Load a new roll of product, making certain that the product stops against the cutter blade (to ensure proper corner length).
4. Press RUN to repeat the corner or press ENTER to skip to the next corner.