

Plywood Backing

Install plywood backing with appropriate thickness to create wall surface that vertically aligns with plaster or hardboard (stucco) siding.

Anchor Sheet or Base Ply, Field

Mechanically attach or fully adhere (self-adhered, torch, cold process or hot asphalt). Proper attachment of the base layer is defined by specified system, product selection and deck type.

Cap Sheet, Field

Fully adhere (self-adhered, torch, cold process or hot asphalt). Proper attachment is defined by product selection. Extend base ply and cap sheet 2" above cant strip; adhere to cant strip only.

Base Flashing

WALL ATTACHMENT: Mechanically attach Anchor 12" o.c. or self-adhere Base Ply; Fully adhere Cap (self-adhered, torch-weld, cold process or hot asphalt; Gang fasten Base and Cap at top edge 9" o.c. with tin discs; Ensure 1.4" bleed out on top edge or apply FlintBond® Caulk.

FIELD ATTACHMENT: Treat the granulated surface of Cap Sheet, Field, where the Base Flashing overlap occurs: **If self-adhered or using cold process** apply FlintBond Trowel to entire lapped surface with 1/4" bleed out or (in cold weather¹) hot air weld² with bead of FlintBond Caulk at edge; **If torch-welded (cap only³)** heat sink/scrape the granules with heated trowel or granular embedment tool and ensure 1/4" bleed out; **if using hot asphalt** apply to entire lapped surface with 1/4" bleed out.

"Z" Bar Counterflashing

Fit top flange into channel behind plaster or hardboard (stucco) siding.

#15 Asphalt Felt

Loose lay, turn over outside edge 2". Gang fasten with Cleat both sides.

CertainTeed recommends strapping all Base Flashing and Counterflashing rolls, running the width of the roll up or perpendicular to the vertical surface.

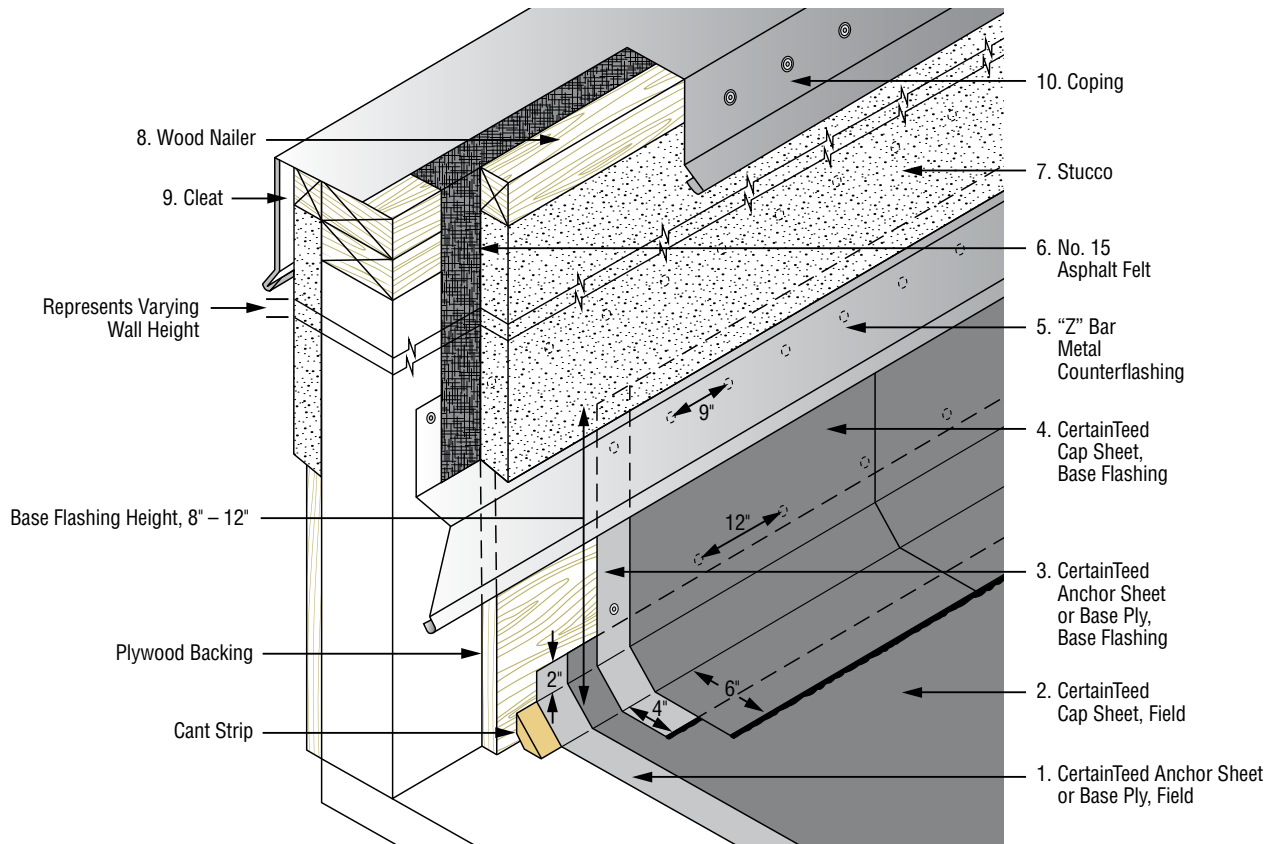

NOT DRAWN TO SCALE

¹20°F-49°F (-6.6°C-4.4°C)

²Apply heat from a hot-air welder with a 2" tip to the overlapped granular surface while applying rolling pressure from a silicone roller to the overlapping Cap. With the hot air welder set between 900°F-1,100°F (setting 8-10), apply heat to the overlap interface while bonding Cap with rolling pressure on the granulated surface. Roll the overlapping Cap in place, moving the hot air welder to allow for forward progress. Avoid applying so much heat or moving at a pace that results in smoke. Apply a bead of FlintBond Caulk along the edge. Continue overlap application, 2" per pass.

³When potential fire hazards can be mitigated CertainTeed considers it acceptable to direct torch provided low output (50,000 BTU or less) equipment is used; when potential fire hazards cannot be mitigated indirect torching methods should be utilized.