

SECTION 'A'
SCALE: 3" = 1'-0"

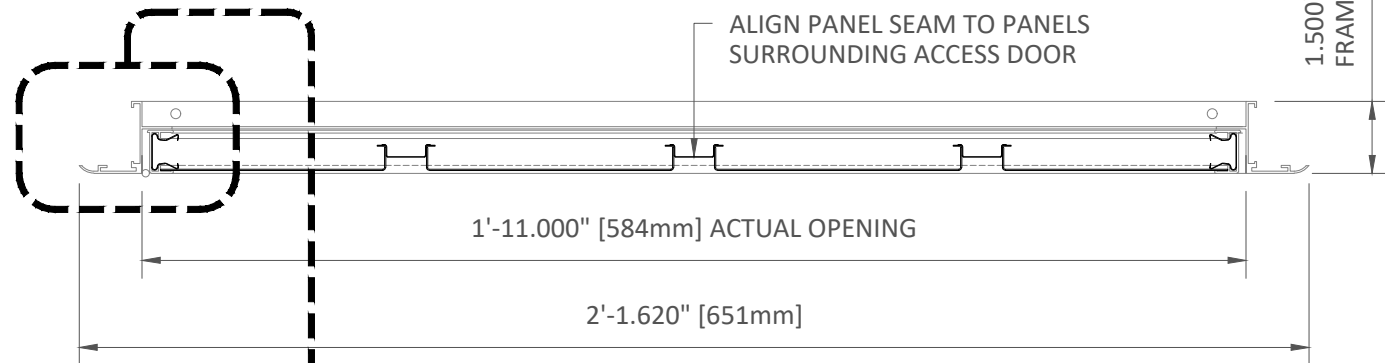

SECTION 'B'
SCALE: 3" = 1'-0"

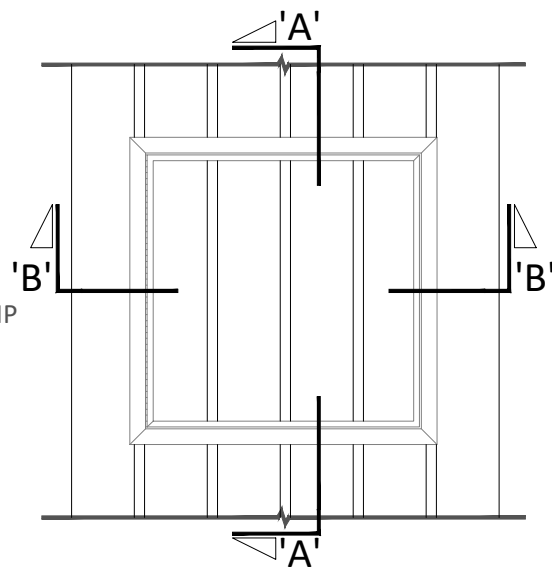
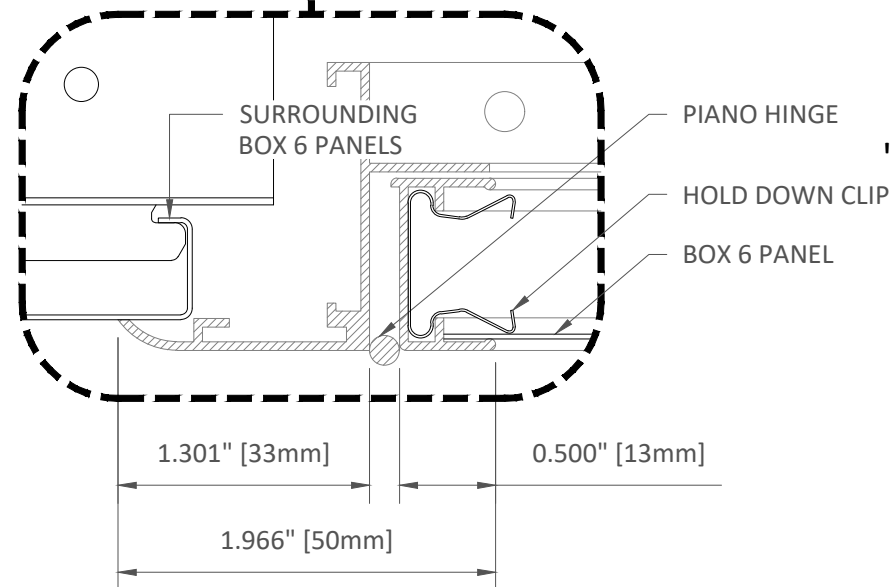

VIEW FROM BELOW:
SCALE: NOT TO SCALE

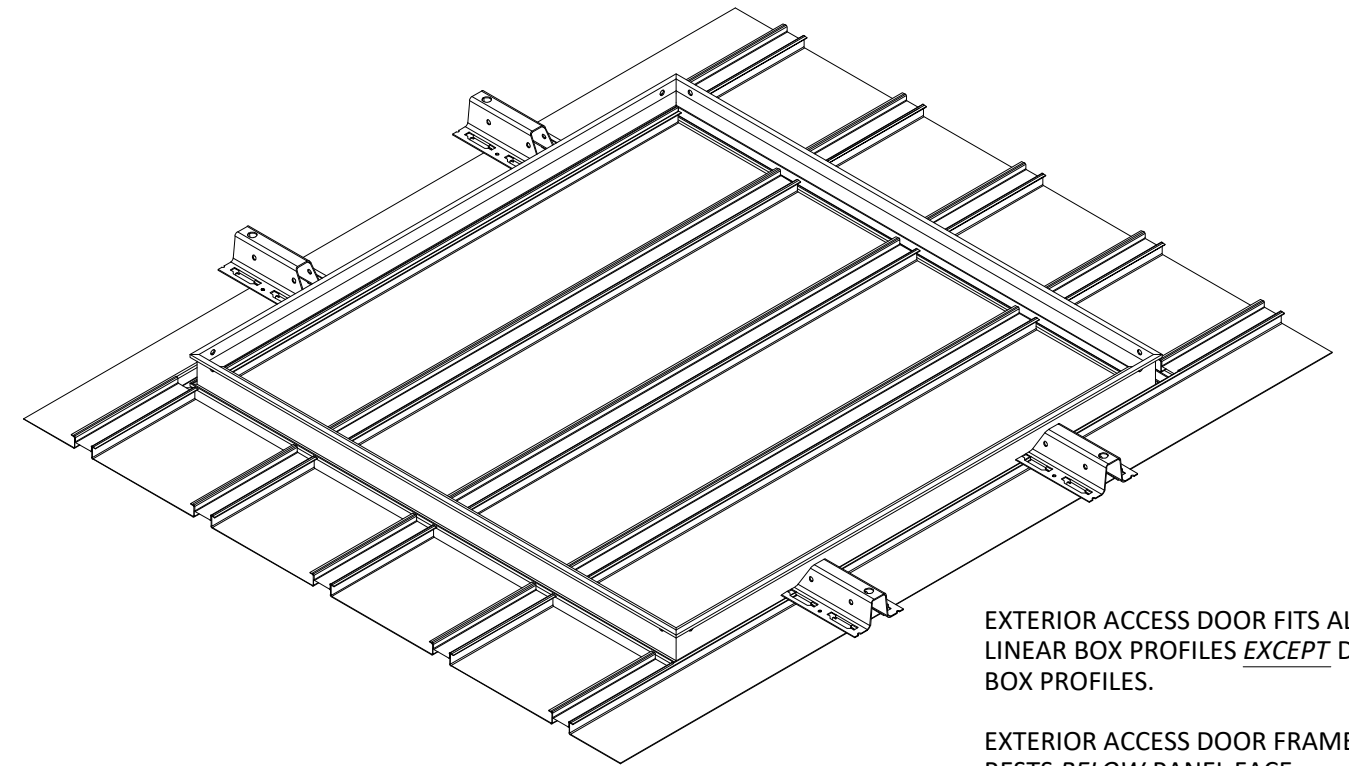

EXTERIOR ACCESS DOOR FITS ALL LINEAR BOX PROFILES EXCEPT DEEP BOX PROFILES.

EXTERIOR ACCESS DOOR FRAME RESTS BELOW PANEL FACE.

EXTERIOR ACCESS DOOR IS EXPOSED FROM BELOW.

PANEL LENGTHS MUST BE FIELD-CUT.

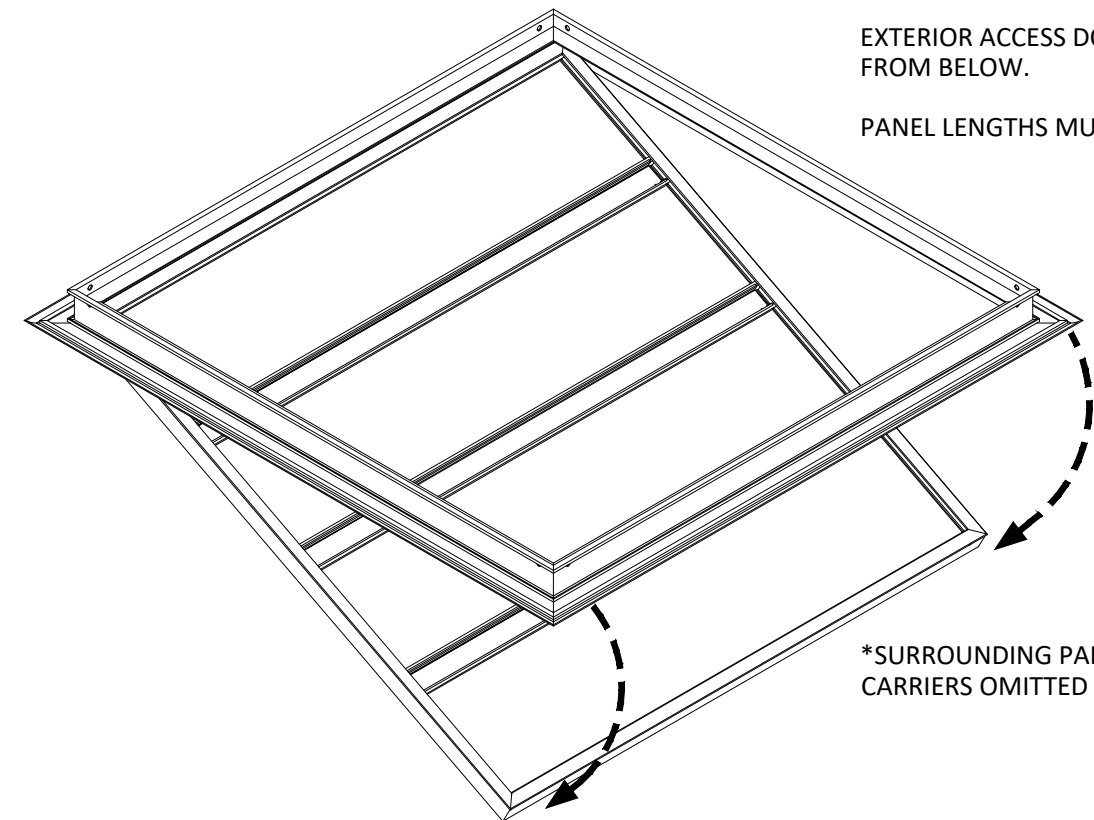

*SURROUNDING PANELS AND CARRIERS OMITTED FOR CLARITY

EXTERIOR INSTALLATION

ARCHITECTURAL

CertainTeed
SAINT-GOBAIN

5015 Oakbrook Parkway, Suite 100
Norcross, GA 30093
O 800 366 4327
F 770 806 0214
www.certainteed.com/architectural

SPECIFICATIONS
(unless noted otherwise)

MATERIAL: .025" | .032" | .040" ALUMINUM BOX 6 PANEL | .040" ALUMINUM UNIVERSAL CARRIER
FINISH: PAINT | POWDER COAT | DECORATED WOOD FINISH | LUXACOTE
PERFORATION: NON-PERFORATED | #160

2'-0" X 2'-0" EXTERIOR ACCESS DOOR

PROJECT: EXTERIOR BOX 6 PRODUCT SPECIFICATIONS
DRAWING NUMBER: BOX6_EXTACCESSDOOR_CTC_2204
SCALE: AS SHOWN
DRAWN BY: CTA ENGINEERING
DATE: 4/20/22

These drawings show typical conditions for installing the CertainTeed product shown. They should not be construed as a substitute for an architectural or engineering design and do not reflect the unique requirements of local codes, laws, statutes or regulations that may be applicable for a specific installation. CertainTeed assumes no liability for the accuracy or completeness of the drawings for a specific installation or the fitness of the drawings for a particular purpose. The user is advised to consult with local licensed design professionals in order to assure compliance with all legal requirements. CertainTeed is not licensed to provide professional engineering or architectural services.