



SilentFX[®] QuickCut[™]

Noise-Reducing Drywall



Dependability when it matters most



The walls you build are constructed with precision and hard work. The products you use need to bring that same level of performance. That's why we offer a full range of reliable drywall and finishing solutions that make installations faster and simpler, all while helping you keep pace with demand — no matter the size, complexity, or location of the project.

Our drywall solutions are manufactured with quality and consistency, and our products are readily available, no matter where you are in the country. Plus, our in-house technical support team is at the ready to help you through even the most demanding installations. We have your back, so you can easily stay on schedule, within budget, and keep your projects running smoothly.

BIM/CAD INFORMATION

The BIM and CAD UL fire rated assemblies and sound assemblies can be found on CertainTeed's BIM and CAD Design Studio at bimlibrary.saint-gobain.com/certainteed. CertainTeed's BIM and CAD Design Studio provides BIM and CAD details to many UL fire rated assemblies and sound assemblies in an easy to view experience. Plus, downloadable Revit and DWG and PDF CAD Details are available.

SUSTAINABILITY

Can contribute to the U.S. Green Building Council's LEED Credit Qualification in several credit categories to assist in obtaining LEED certification. Sustainable documentation, including recycled content, EPDs, HPDs, VOC Certifications, can be found at saintgobain.ecomedes.com.



Building responsibly

CertainTeed respects the environment through the responsible development of sustainable building products and systems.

The building industry continues to look for ways to reduce impact on the environment while meeting customer demand for products that deliver beauty, comfort and performance.

CertainTeed's commitment to these goals is reflected here, highlighting our ongoing effort to become the preeminent supplier of green building materials.

Awareness of the importance of acoustics in sustainable construction continues to grow, and this is evident with the inclusion of sustainability requirements in many building programs and codes:

LEED v4.1

- IEQ Credit 9
Acoustic Performance
- MR Credit: Building Product Disclosure and Optimization—Environmental Product Declarations. On many of our products, valued as 1.5 products with our Product-Specific Type II EPDs.
- MR Credit: Building Product Disclosure and Optimization—Materials Ingredients. On many of our products, valued as 1.5 products with our 3rd Party Verified HPDs.

GREEN GUIDE FOR HEALTH CARE

- EQ Credit 9.1
Acoustic Environment

2015 INTERNATIONAL GREEN CONSTRUCTION CODE (IGCC)

- Section 3.3
Acoustical Control

WELL v1:

- #1 - Air: Air Quality Standards
- #4- Air: VOC Reduction
- #11 - Air: Fundamental Material Safety
- #25 - Air: Toxic Material Reduction
- #26 - Air: Enhanced Material Safety
- #74 - Comfort: Exterior Noise Intrusion
- #81 - Comfort: Sound Barriers
- #97 - Mind: Material Transparency



REVIEW SYSTEMS PERFORMANCE INFORMATION TO SEE HOW SILENTFX® QUICKCUT™ SYSTEMS CAN HELP CONTRIBUTE TO THESE SUSTAINABLE PROGRAMS.



The Health Product Declaration® logo is a trademark or service mark of Health Product Declaration Collaborative, Inc., in the United States and in other countries and is being used herein under license.

USGBC® and the related logo are trademarks owned by the U.S. Green Building Council® and are used with permission.

Hear is what matters

Acoustics is the scientific study of sound. The majority of architectural acoustic situations consist of a source, a path and a receiver. The source can be the neighbors' home theater system, a patient waiting room or the high school band practice room. The receiver can be a person trying to talk on the phone, sitting in an examination room or conducting a class. The sound transmission paths are those building elements through which noise from the source travels to interfere with our daily activities. SilentFX® QuickCut™ drywall panel systems address these paths and through proper design and installation contribute to satisfactory sound isolation and privacy.

DECIBEL (dB)

A measurement of sound intensity or loudness. The more intense the sound, the higher the dB level.

AIRBORNE VS. STRUCTUREBORNE SOUND

Airborne: Sound transmitted through air.
Structureborne: Sound transmitted through structure of building.

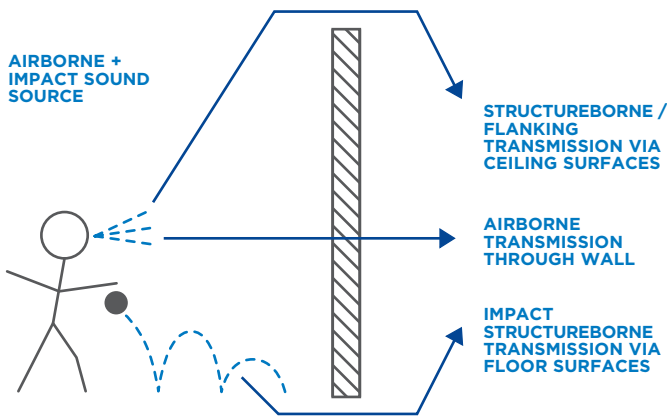

Some key performance characteristics of good acoustic design are to provide mass to the system with the ability to dampen vibrations caused by sound energy striking the system. SilentFX® QuickCut™ drywall panel is engineered using the mass of two dense gypsum layers with an inner layer of viscoelastic polymer that acts much like a shock absorber to dampen board vibrations. This type of “Constrained Layer Damping” board product performs well acoustically over an extended range of frequencies, resulting in increased Sound Transmission Class (STC) ratings for the systems.

SOURCE ROOM	RECEIVING ROOM	MIN. STC*
SCHOOL		
Classroom	Adjacent Classroom	STC 42
	Speech use only	
	Speech + Audiovisual	
	Corridor, public area	
	Recreational area	STC 52+
DOCTOR'S SUITE		
Office	Adjacent offices	STC 52
	Corridor, lobby	STC 52
	Mechanical	STC 52+
HOTEL		
Bedroom	Adjacent bedroom	STC 48+
	Corridor, lobby, public area	STC 48+
	Mechanical	STC 52+
MULTI-FAMILY HOME		
Bedroom	Adjacent Bedroom	STC 48-55
	Living room, separate occupancy	STC 50-57
	Corridor, lobby, public area	STC 48-55
	Exterior of building	STC 42-60

* Recommended minimum STC

Noise leaks and flanking paths

Noise leaks, as the term implies, are the result of situations such as unsealed gaps at wall/wall, wall/floor and wall/ceiling junctures, medicine cabinets installed back to back and electrical outlets on each side of a wall sharing the same stud cavity. Flanking paths are those indirect routes that noise can follow to an adjacent room or dwelling, such as openings under doors, air ducts and floors under a common wall. Reducing or eliminating through-wall penetrations and restricting wall penetrations to one per stud cavity assists in achieving the acoustical performance of the wall system. Such noise problems can be greatly reduced by thoughtful planning in the early stages of the building's design and close supervision with proper attention to small details during construction.

SOUND TRANSMISSION CLASS (STC) RATING

A single number rating system that represents the sound transmission loss performance of a wall.

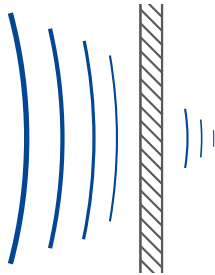

AMBIENT NOISE

All sound in a given environment, including sound from outdoors, building services and utilities.

	PERCEPTION OF SOUND PRESSURE	SOUND PRESSURE LEVEL (dB)
PAIN THRESHOLD		140
JET TAKE-OFF	INTOLERABLE	130
		120
ROCK CONCERT	DEAFENING	110
		100
STREET TRAFFIC	VERY LOUD	90
		80
PHONE RINGING	LOUD	70
TV / BUSY OFFICE		60
NORMAL CONVERSATION	MODERATE	50
		40
QUIET ROOM	FAINT	30
		20
CALM BREATHING	VERY FAINT	10
		0
HEARING THRESHOLD		0

SilentFX® QuickCut™

Noise-Reducing Drywall Panels — for the best in acoustic management

CertainTeed's SilentFX® QuickCut™ drywall panels are noise-reducing panels specifically designed for systems requiring high Sound Transmission Class (STC) ratings.

SilentFX® QuickCut™ noise-reducing drywall panel is specifically designed to reduce airborne sound transmission between two adjoining spaces when used in wall or floor/ceiling assemblies. SilentFX® QuickCut™ drywall panel features a viscoelastic polymer that installs and finishes like standard drywall, and dampens sound energy.

Application of the viscoelastic polymer between two specially formulated dense gypsum cores results in a combination that significantly improves sound attenuation and is ideal for systems requiring high STC performance. Commercial acoustic systems featuring SilentFX® QuickCut™ drywall panel provide STC ratings of 50 and up. In addition to providing exceptional acoustic performance, this functionally superior board is engineered to install and finish like standard drywall.

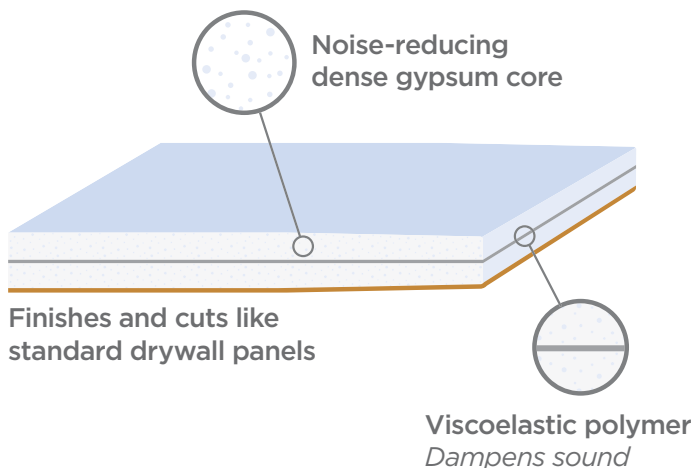

M2TECH™
Mold and moisture

*** Results are reflective of samples prepared with 1 coat primer and 1 coat semi-gloss latex paint

SILENTFX® QUICKCUT™ FINISHES LIKE STANDARD DRYWALL

ENHANCED ACOUSTICAL PERFORMANCE
STC ratings of 50 and greater

ENHANCED FIRE RESISTANCE
Available in 5/8" Type X,
UL/cUL Classified and ULC Listed

MOLD RESISTANCE
Best possible score per ASTM D3273

ABUSE RESISTANCE
Per ASTM C1629

1/2"
Surface Abrasion: 3***
Soft Body: 1

5/8"
Surface Abrasion: 3***
Soft Body: 3
Hard Body: 3

LOW-EMITTING MATERIAL
GREENGUARD® Gold Certified

HIGH-DENSITY CORE
Provides increased mass

3RD PARTY VERIFIED HEALTH PRODUCT DECLARATIONS (HPDs)

PRODUCT-SPECIFIC TYPE III ENVIRONMENTAL PRODUCT DECLARATIONS (EPDs)



SilentFX® QuickCut™

Noise-Reducing Drywall Panel — acoustic solutions without complex techniques

SilentFX® QuickCut™ drywall panels are an excellent acoustic solution for meeting STC specifications without complex techniques such as isolation clips or resilient channels. It can also help reduce material usage versus traditional gypsum systems that require high sound attenuation.

MORE RELIABLE THAN CLIPS AND CHANNELS

Clips and resilient channel can easily be short-circuited during the construction process and even afterwards, during picture hanging or pressing of heavy objects against the wall, negatively affecting acoustic performance. These risks are eliminated when using SilentFX® QuickCut™ drywall panels, thus providing more consistent acoustic performance. When used in systems with resilient channel, SilentFX® QuickCut™ Drywall Panels, can reduce the negative effect of short circuits.

DOUBLE LAYER CERTAINEED 5/8" TYPE X

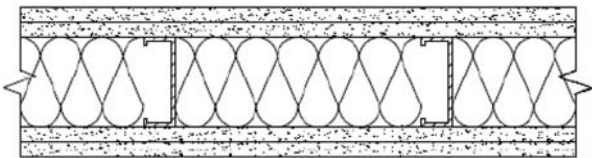

DOUBLE LAYER CERTAINEED 5/8" TYPE X

Thickness: 6-1/8"
Acoustic rating: STC 56
Sound test: NOAL 19-0602

SQUARE-FOOT SAVINGS

The high acoustic performance of SilentFX® QuickCut™ drywall panels make it possible to build effective noise-reducing walls with less material, gaining valuable floor square footage, and saving both construction time and material cost. Less material used also means a more sustainable structure in keeping with today's green building practices.

SINGLE LAYER SILENTFX® QUICKCUT™ 5/8" TYPE X

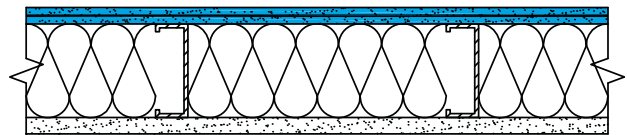

SINGLE LAYER CERTAINEED 5/8" TYPE X

Thickness: 4-7/8"
Acoustic rating: STC 56
Sound Test: OL 17-0221



Rx Symphony[®] m
Mineral Fiber Ceilings

silentFX
QuickCut[™]

CertainTeed[®] Fiber
Glass Insulation

A quiet place to heal.

Healthcare facilities need to provide an oasis of quiet — conducive to healing. They are also under pressure to reduce costs and be more responsive to patients. In hospitals with reduced noise levels, patient satisfaction with caregiving is increased and sleep is improved. This leads to faster healing, which can mean shorter stays and reduced costs for both patients and hospitals.

BENEFITS FOR HEALTHCARE FACILITIES

Improves patients' sleep and healing time, leading to reduced costs

Increases staff job satisfaction, which can reduce turnover

Helps meet HIPAA acoustic privacy regulations

Symphony® f
Fiberglass Ceilings

CertainTeed® Fiber
Glass Insulation

silentFX®
QuickCut™

More learning with less distraction.

Learning depends on communication between teachers and students. Excessive noise creates a barrier to learning. Noise such as conversations in hallways, sound systems, students in other classrooms and mechanical equipment can hamper student concentration. Background noise causes teachers to raise their voices, which results in vocal strain over time. SilentFX® QuickCut™ drywall panels specifically reduce sound transmission from adjacent spaces to make it easier for teachers to be heard and students to learn.

BENEFITS FOR SCHOOLS

Reduces distractions so students can pay closer attention and learn more effectively

Keeps the lines of communication between students and teachers clear and open

Reduces teacher voice strain and increases effectiveness



silentFX®
QuickCut™

CertainTeed® Fiber
Glass Insulation

Get away from it all.

A hotel's most important promise to its guests is privacy and relaxation. Guests who feel relaxed and refreshed are more likely to return and recommend the hotel to others. Yet by nature, hotels are busy, noisy places. People come and go around the clock, vacuums whirr, foot traffic and conversations can be heard up and down hallways. SilentFX® QuickCut™ drywall panels enhance the guest experience by providing a sound-buffered oasis of comfort amid the hustle and bustle of the busiest hotel.

BENEFITS FOR HOTELS

Helps guests feel relaxed and comfortable so they want to return

Isolates noise from other guest rooms, service corridors and mechanical equipment

Reduces disruptions and distractions in conference rooms and other meeting spaces

CertainTeed® Fiber
Glass Insulation

silentFX®
QuickCut™

Never hear the neighbors.

In a home, good acoustics are even more important to ensure quality of life. SilentFX® QuickCut™ reduces noise between residential units to increase the sense of separation from neighbors that is necessary for comfort and privacy. SilentFX® QuickCut™ drywall panel systems, with an STC rating of 50 or higher, substantially decrease sound transmitted through walls and improve residents' satisfaction, which leads to less turnover and fewer expenses associated with filling vacancies.

BENEFITS FOR MULTI-FAMILY HOMES

Minimizes neighborhood noise

Increases community harmony

Improves resident satisfaction and peace of mind

Product specifications

SilentFX® QuickCut™ noise-reducing drywall panels are manufactured in nominal 1/2" and 5/8" Type X, 48" width by 8', 9', 10' and 12' lengths.

	1/2" SILENTFX® QUICKCUT™	5/8" SILENTFX® QUICKCUT™ TYPE X
Product Standards	ASTM C1766; C1629	ASTM C1766; C1629
Application Standards	ASTM C840; GA-216	ASTM C840; GA-216
Widths	48"	48"
Standard Lengths*	8'	8'
	9'	9'
	10'	10'
	12'	12'
Weight	2.1 lb/ft ²	2.8 lb/ft ²
Edges	Tapered	Tapered
Flame Spread (ASTM E84)	0	0
Smoke Developed (ASTM E84)	0	0
Mold Resistance Rating** (ASTM D3273)	10	10
Abuse Resistance Classifications (ASTM C1629)		
Surface Abrasion	3***	3***
Soft Body Impact	1	3
Hard Body Impact	—	3

The performance of SilentFX® QuickCut™ noise-reducing drywall panel in actual use may not accurately reproduce these ASTM laboratory test results. Good design and construction practices that prevent exposure of building products to water and moisture are the most effective strategy to avoid mold growth.

* Special lengths or edges may be available as a special order. Please contact your CertainTeed Representative.

Standard lengths may differ by region, please contact your sales rep for more information.

** No mold growth detected. Note: 10 is the best possible rating for ASTM D3273.

*** Results are reflective of samples prepared with 1 coat primer and 1 coat semi-gloss latex paint



SilentFX® QuickCut™
Type X drywall has
excellent acoustic
properties for meeting
and exceeding STC
specifications.

Installation and finishing

SilentFX® QuickCut™ drywall panels are installed following traditional methods of application and finishing of interior drywall products for both walls and ceilings.

INSTALLATION

1/2" SilentFX QuickCut drywall is for use on interior walls in residential, commercial and institutional applications.

5/8" SilentFX QuickCut Type X drywall is for use on interior walls and ceilings in residential, commercial and institutional applications.

- Plan SilentFX QuickCut drywall layout to stagger joints from one side of the wall to the other and stagger between board layers for multi-layered assemblies
- Install batt insulation (CertainTeed's thermal and acoustical fiber glass insulation or equivalent) in cavities
- Use Green Glue® noiseproofing sealant, or equivalent acoustic sealant, to seal electrical outlet boxes
- Install SilentFX QuickCut drywall panels in accordance with GA-216, *Application and Finishing of Gypsum Panels* (ASTM C840)
- Allow a 1/4" gap around all wall perimeter edges
- SilentFX QuickCut boards are cut by scoring from the face side and snapping the same as standard drywall panels
- Seal the 1/4" perimeter gaps and wall penetrations per ASTM C919 with Green Glue or equivalent acoustical sealant

FINISHING

SilentFX QuickCut drywall panel may be finished, painted or wallpapered using conventional drywall finishing techniques. The Gypsum Association GA-214, "Recommended Levels of Drywall Panel Finish" should be referenced when specifying the level of finishing desired.

FIRE-RATED ASSEMBLIES

For the installation of fire-rated assemblies, refer to the appropriate UL/cUL or ULC design in the UL/ULC Fire Resistance Directories for details such as board orientation and fastening schedules.

The UL/ULC Type Designation for 5/8" SilentFX QuickCut Type X is Type SilentFX.



SilentFX® QuickCut™ drywall panels are engineered to install and finish like standard gypsum board.

Sound isolation construction

“NORMAL CONSTRUCTION”

Not suitable for good sound control.
Arrows show flanking paths

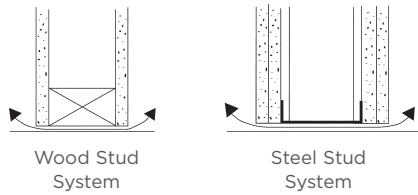

Elevation
Under and Over Partitions

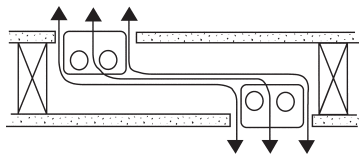

Plan
Through Partitions, Openings,
Outlet Boxes

Window Mullion

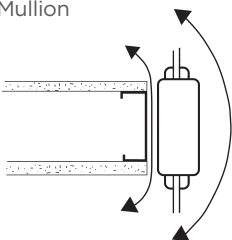

Plan
Around Flanking Partition Ends

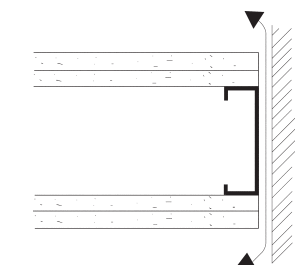

Plan
Metal Stud
Around Flanking Partition Ends

“SELECT CONSTRUCTION”

Caulking of relief detail at perimeter
of partition to prevent sound leakage

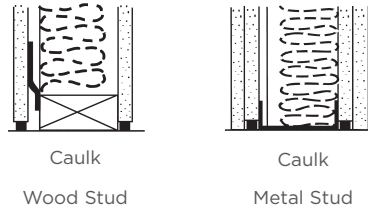

Elevation

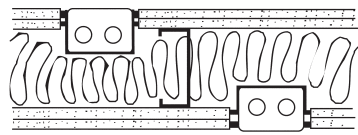

Plan
Indicating Caulking of Openings
Through Partitions

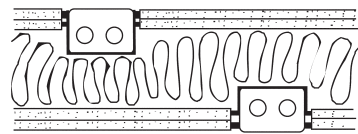

Plan
Intersection With Interior Wall

“PRE-DESIGN” CONSTRUCTION

Simulating laboratory conditions

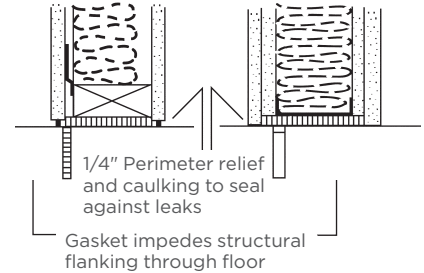

Elevation
Typical Floor-Ceiling or Roof Detail

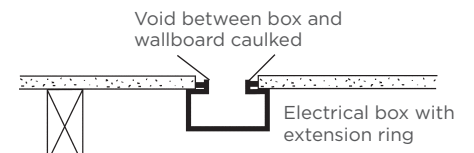

Plan
Outlet Box Detail

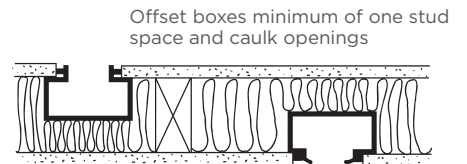

Plan
Intersection With Exterior Wall

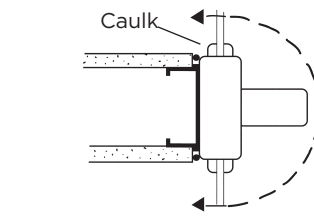
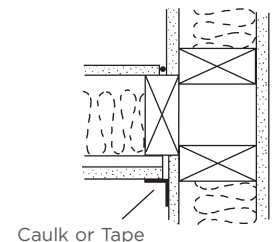

Plan
Typical Partition Mullion Intersection

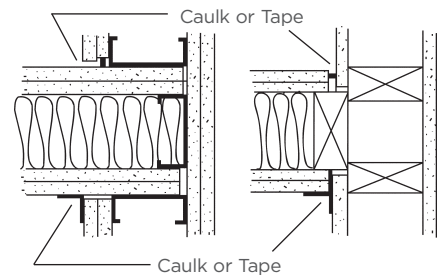
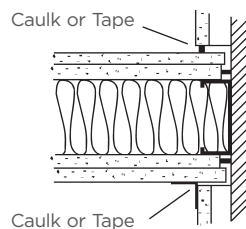

Plan
Typical Partition Intersections

Impact of sealing on reducing flanking noise

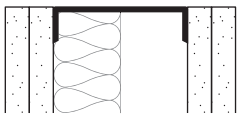
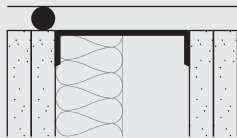
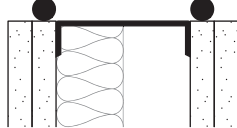
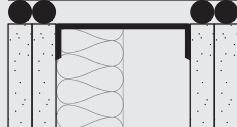
	EDGE DETAIL	STC VALUE	COMMENTS
	Unsealed	29	The open-edge track gave the STC value of 29 through direct leakage
	Single sealant at the perimeter of one base layer	49	The bead closed void but did not seal leakage around the joint between the wallboard and track
	Two sealants, one for each base layer of gypsum board	53	The beads closed void and sealed leakage around track
	Four sealants, one for each base and face layer of gypsum board	53	The void is closed; no leaks around track and wallboard

Courtesy of the Gypsum Association

Techniques for maintaining STC performance

STAGGERED OUTLETS

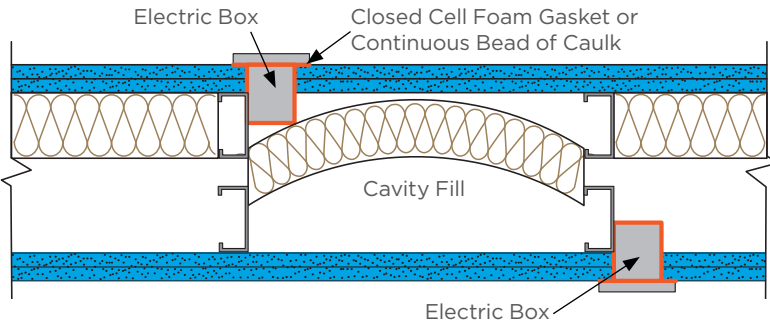

Air seal electrical outlets. Stagger outlet locations to reduce direct sound paths.

NON-STAGGERED OUTLETS

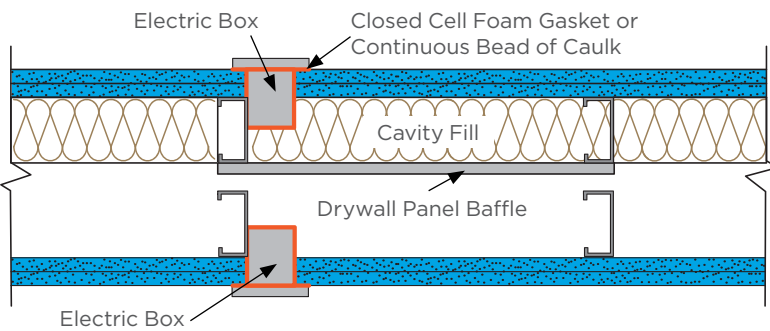

If outlets are not staggered, block direct paths between outlets with sound barrier.

STAGGERED GYPSUM

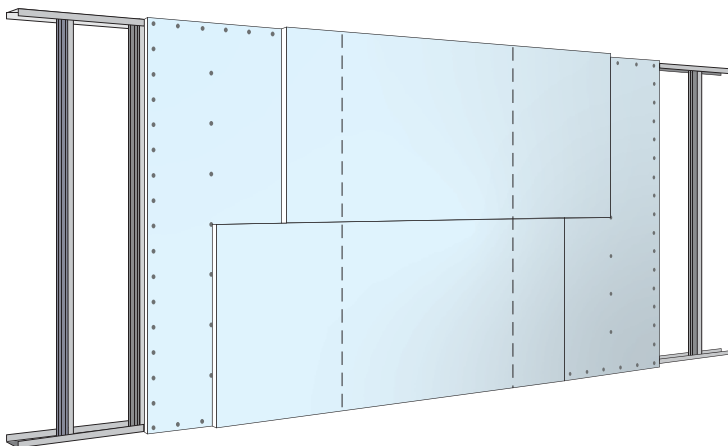

Stagger gypsum board joints to reduce sound transmission

ACOUSTICAL SEALANT

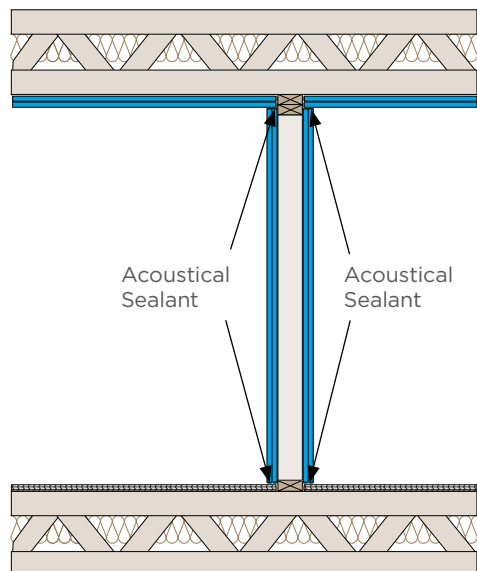

Use Acoustical Sealant around perimeter gaps and wall penetrations

Acoustic assembly key

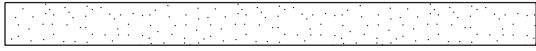

Gypsum Plaster
Gypsum Floor Underlayment
Gypsum Panel Product

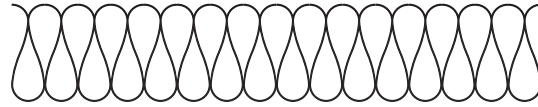

Glass Fiber or Mineral Wool Insulation

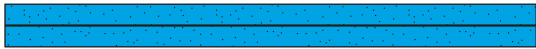

Factory-Laminated Gypsum Panel Product

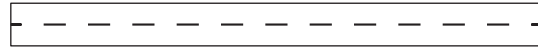

Resilient Channel
(Plan)



Wood Structural Panel
(OSB, Plywood, Etc.)

SilentFX[®] QuickCut[™]
noise-reducing
drywall panels —
specifically designed
for quiet environments.

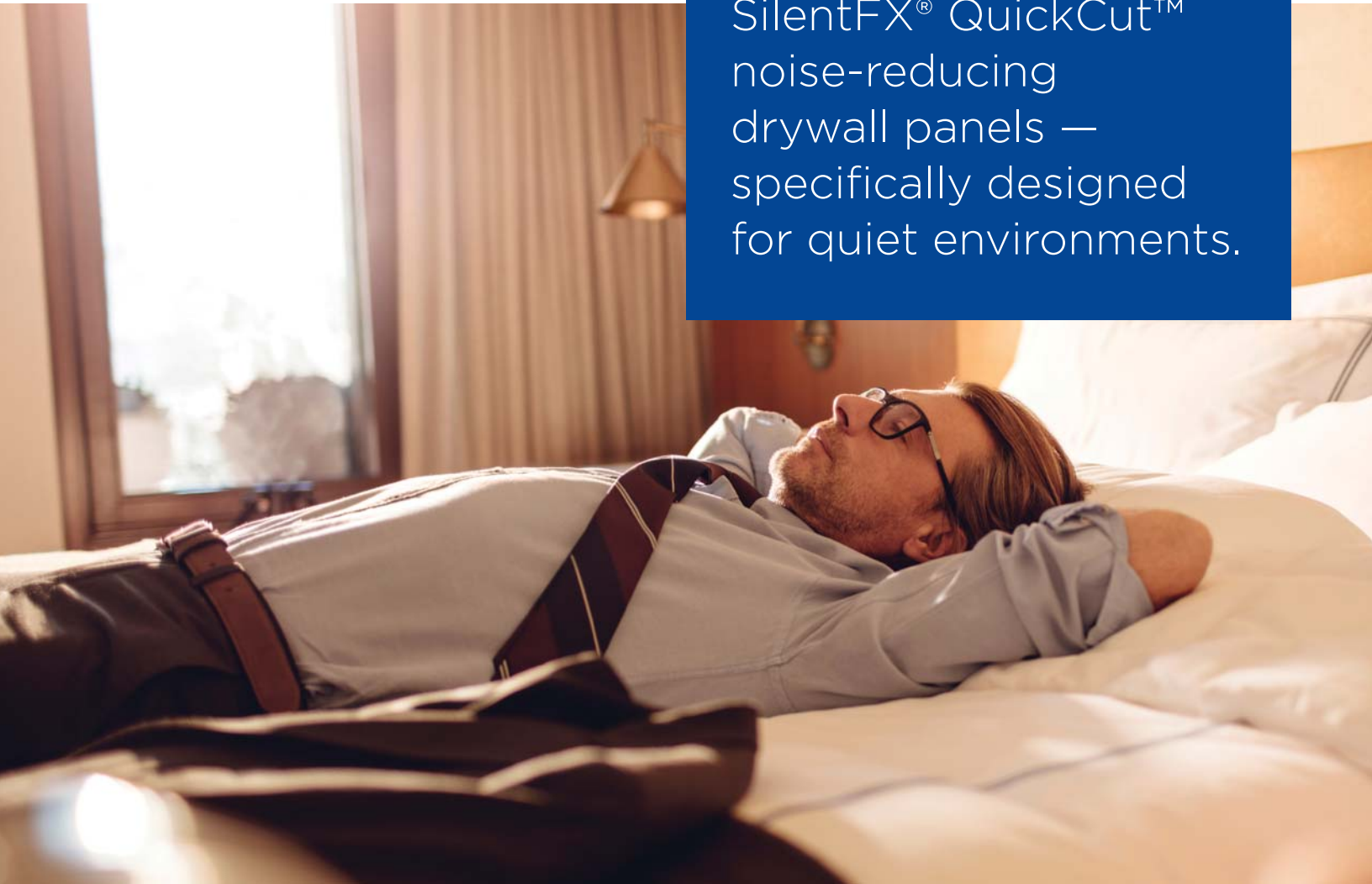

1/2" SILENTFX® QUICKCUT™ - WOOD STUD SYSTEMS

16" o.c. - 2" x 4"

A Nominal 2"x4" wood studs 16" o.c.

ONE SIDE

B 1/2" SilentFX QuickCut applied with 1-1/4" type W screws 16" o.c.

OPPOSITE SIDE

C 1/2" Easi-Lite® drywall applied with 1-1/4" type W screws 16" o.c. All joints staggered.

D 3-1/2" CertainTeed® Fiber Glass Insulation or equivalent.

STC RATING

41

OL 17-0328

FIRE RATING

N/A

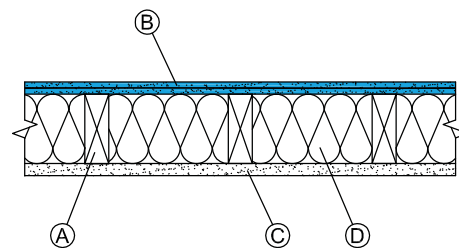

24" o.c. - 2" x 4"

A Nominal 2"x4" wood studs 24" o.c.

ONE SIDE

B 1/2" SilentFX QuickCut applied with 1-1/4" type W screws 16" o.c.

OPPOSITE SIDE

C 1/2" Easi-Lite® drywall applied with 1-1/4" type W screws 16" o.c. All joints staggered.

D 3-1/2" CertainTeed® Fiber Glass Insulation or equivalent.

STC RATING

50

OL 17-0208

FIRE RATING

N/A

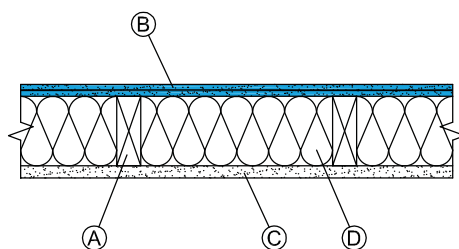

A Nominal 2"x4" wood studs 24" o.c.

ONE SIDE

B 1/2" SilentFX QuickCut applied with 1-1/4" type W screws 16" o.c.

OPPOSITE SIDE

C 1/2" SilentFX QuickCut applied with 1-1/4" type W screws 16" o.c. All joints staggered.

D 3-1/2" CertainTeed® Fiber Glass Insulation or equivalent.

STC RATING

54

OL 17-0211

FIRE RATING

N/A

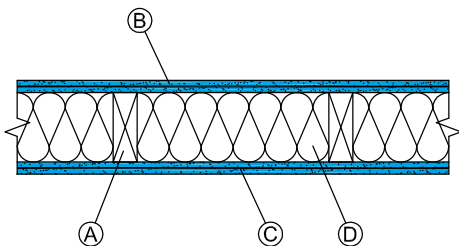

5/8" SILENTFX® QUICKCUT™ - WOOD STUD SYSTEMS

16" o.c. - 2" x 4" - 1 hr fire rating

A Nominal 2"x4" wood studs 16" o.c.

ONE SIDE

B 5/8" SilentFX QuickCut Type X applied with 1-1/4" type W screws 8" o.c.

OPPOSITE SIDE

C 5/8" CertainTeed® Type X applied with 1-1/4" type W screws 8" o.c. All joints staggered.

D 3-1/2" CertainTeed® Fiber Glass Insulation or equivalent.

STC RATING

40

NOAL 21-0658

FIRE RATING

1 hr.

UL/cUL U305

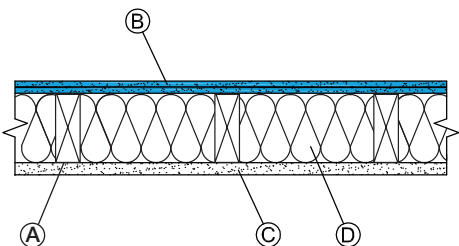

NOTE: SilentFX® QuickCut™ drywall panels can be used as either the base or face layer in a multi-layer system without affecting the STC rating. Equivalent fiber glass insulations may be substituted for CertainTeed Insulation products.

5/8" SILENTFX® QUICKCUT™ - WOOD STUD SYSTEMS

A Nominal 2"x4" wood studs 16" o.c.

ONE SIDE

B 1/2" plywood applied with 1-7/8" nails 6" o.c. perimeter and 12" o.c. field

C 5/8" Type X applied with 2-3/8" nails 7" o.c.

OPPOSITE SIDE

D 5/8" SilentFX QuickCut Type X applied with 1-1/4" type W screws 8" o.c. All joints staggered.

E 3-1/2" CertainTeed® Fiber Glass Insulation or equivalent.

STC RATING

45

NOAL 18-0315

FIRE RATING

1 hr.

UL/cUL U305

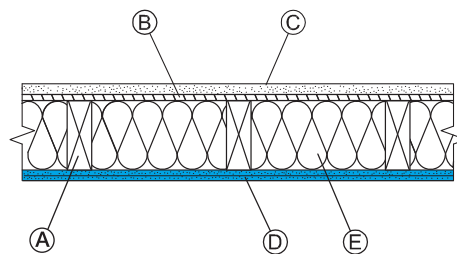

A Nominal 2"x4" wood studs 16" o.c.

ONE SIDE

B 5/8" SilentFX QuickCut Type X applied with 1-1/4" type W screws 12" o.c.

OPPOSITE SIDE

C 5/8" SilentFX QuickCut Type X applied with 1-1/4" type W screws 12" o.c. All joints staggered.

D 3-1/2" CertainTeed® Fiber Glass Insulation or equivalent.

STC RATING

45

OL 17-0219

FIRE RATING

1 hr.

UL/cUL U305

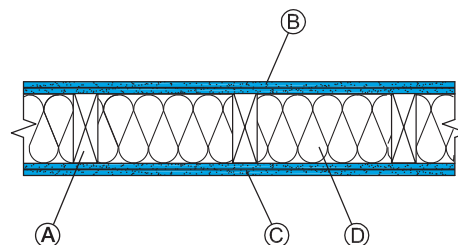

A Nominal 2"x4" wood studs 16" o.c.

ONE SIDE

B Resilient channel 24" o.c.

C 5/8" SilentFX QuickCut Type X applied with 1" type S screws 8" o.c.

OPPOSITE SIDE

D 5/8" CertainTeed® Type X applied with 1-1/4" type W screws 8" o.c. All joints staggered.

E 3-1/2" CertainTeed® Fiber Glass Insulation or equivalent.

STC RATING

52

OL 18-0819

FIRE RATING

1 hr.

UL/cUL U305

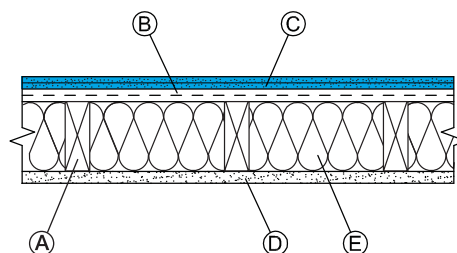

A Nominal 2"x4" wood studs 16" o.c. staggered 8" o.c. on 6" plates.

ONE SIDE

B 5/8" SilentFX QuickCut Type X applied with 1-1/4" type W screws 8" o.c.

C 3-1/2" CertainTeed® Fiber Glass Insulation or equivalent.

OPPOSITE SIDE

D 5/8" CertainTeed® Type X applied with 1-1/4" type W screws 8" o.c. All joints staggered.

E 3-1/2" CertainTeed® Fiber Glass Insulation or equivalent.

STC RATING

52

NGC 2016146

FIRE RATING

1 hr.

UL/cUL V432

ULC W313

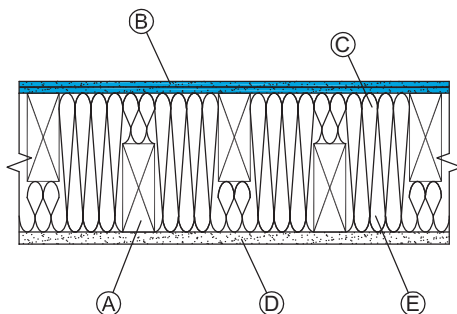

A Nominal 2"x4" wood studs 16" o.c.

ONE SIDE

B Resilient channel 24" o.c.

C 5/8" SilentFX QuickCut Type X applied with 1" type S screws 8" o.c.

OPPOSITE SIDE

D 5/8" SilentFX QuickCut Type X applied with 1-1/4" type W screws 8" o.c. All joints staggered.

E 3-1/2" CertainTeed® Fiber Glass Insulation or equivalent.

STC RATING

54

OL 18-0816

FIRE RATING

1 hr.

UL/cUL U305

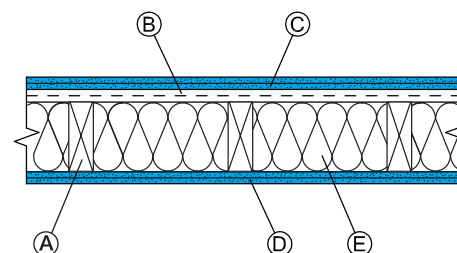

5/8" SILENTFX® QUICKCUT™ - WOOD STUD SYSTEMS

24" o.c. - 2" x 4" - 1 hr fire rating

A Nominal 2"x4" wood studs 24" o.c.

ONE SIDE

B 5/8" SilentFX QuickCut applied with 1-1/4" type W screws 8" o.c.

OPPOSITE SIDE

C 1/2" plywood applied with 1-7/8" nails 6" o.c. perimeter and 12" o.c. in the field

D 5/8" CertainTeed® Type X applied with 2-3/8" nails 7" o.c. All joints staggered.

E 3-1/2" CertainTeed Thermal & Acoustical Fiber Glass Insulation or equivalent.

STC RATING

51
NOAL 18-0316

FIRE RATING

1 hr.
UL/cUL U309
ULC W313

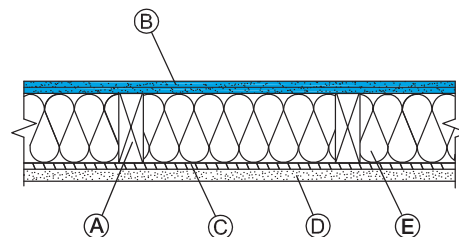

A Nominal 2"x4" wood studs 24" o.c.

ONE SIDE

B Resilient channel 24" o.c.

C 5/8" SilentFX QuickCut Type X applied with 1" type S screws 8" o.c.

OPPOSITE SIDE

D 5/8" CertainTeed® Type X applied with 1-1/4" type W screws 8" o.c. All joints staggered.

E 3-1/2" CertainTeed® Fiber Glass Insulation or equivalent.

STC RATING

52
NOAL 21-0656

FIRE RATING

1 hr.
UL/cUL U309

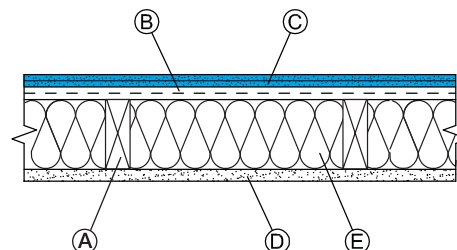

A Nominal 2"x4" wood studs 24" o.c.

ONE SIDE

B 5/8" SilentFX QuickCut Type X applied with 1-1/4" type W screws 12" o.c.

OPPOSITE SIDE

C 5/8" SilentFX QuickCut Type X applied with 1-1/4" type W screws 12" o.c.

D 3-1/2" CertainTeed® Fiber Glass Insulation or equivalent

STC RATING

54
OL 15-1110

FIRE RATING

1 hr.
UL/cUL U309
ULC W313

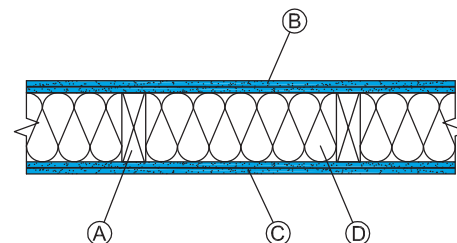

A Nominal 2"x4" wood studs 24" o.c.

ONE SIDE

B Resilient channel 24" o.c.

C 5/8" SilentFX QuickCut Type X applied with 1" type S screws 8" o.c.

OPPOSITE SIDE

D 5/8" CertainTeed SilentFX QuickCut Type X applied with 1-1/4" type W screws 8" o.c. All joints staggered.

E 3-1/2" CertainTeed® Fiber Glass Insulation or equivalent.

STC RATING

55
NOAL 21-0657

FIRE RATING

1 hr.
UL/cUL U309

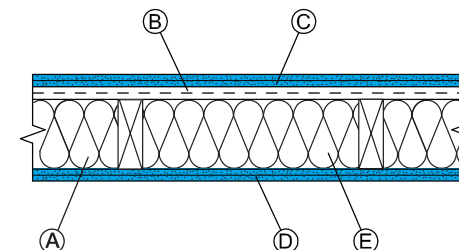

24" o.c. - 2" x 6" - 1 hr fire rating

A Nominal 2"x6" wood studs 24" o.c.

ONE SIDE

B 5/8" SilentFX QuickCut Type X applied with 1-1/4" type W screws 8" o.c.

C 5" CertainTeed® Fiber Glass insulation or equivalent

OPPOSITE SIDE

D 5/8" CertainTeed® Type X applied with 1-1/4" type W screws 8" o.c.

STC RATING

51
OL 18-1020

FIRE RATING

1 hr.
UL/cUL U309

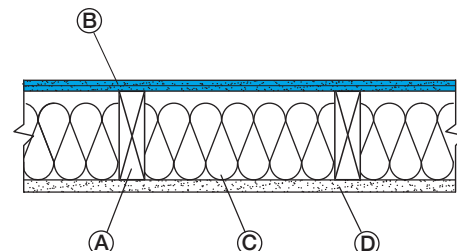

NOTE: SilentFX® QuickCut™ drywall panels can be used as either the base or face layer in a multi-layer system without affecting the STC rating. Equivalent fiber glass insulations may be substituted for CertainTeed Insulation products.

5/8" SILENTFX® QUICKCUT™ - WOOD STUD SYSTEMS

24" o.c. - 2" x 6" - 1 hr fire rating

A Nominal 2"x6" wood studs 24" o.c.

ONE SIDE

B Face layer 5/8" SilentFX QuickCut Type X applied with 1-5/8" 8" o.c.

C Base layer 1/2" plywood applied with nails 4" o.c.

D 6-1/4" CertainTeed® Fiber Glass Insulation or equivalent

OPPOSITE SIDE

E Face layer 5/8" CertainTeed® Type X applied with 1-5/8" type W screws 8" o.c.

F Base layer 1/2" plywood applied with nails 4" o.c. perimeter and 12" o.c. field

STC RATING

52

NOAL 20-1004

FIRE RATING

1 hr.

UL/cUL U309

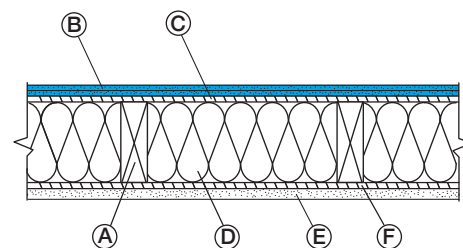

5/8" SILENTFX® QUICKCUT™ - WOOD STUD CHASE WALLS

16" o.c. - 2" x 4" - 1 hr fire rating

A Double row nominal 2"x4" wood studs on separate plates, 16" o.c. with 1" gap.

ONE SIDE

B 5/8" SilentFX QuickCut Type X applied with 1-1/4" type W screws 8" o.c.

OPPOSITE SIDE

C 5/8" CertainTeed® Type X applied with 1-1/4" type W screws 12" 8" o.c. All joints staggered.

D 3-1/2" CertainTeed® Fiber Glass Insulation or equivalent.

STC RATING

60

OL 19-0718

FIRE RATING

1 hr.

UL/cUL V432

ULC W313

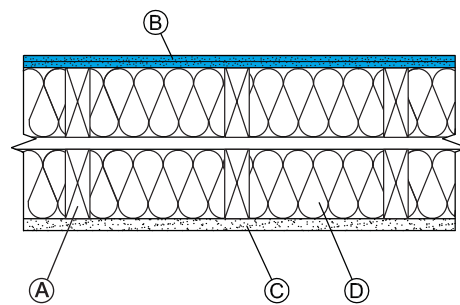

1/2" SILENTFX® QUICKCUT™ - STEEL STUD SYSTEMS

24" o.c.

A 3-5/8" 25 EQ (15 mil) steel studs 24" o.c.

ONE SIDE

B 1/2" SilentFX QuickCut applied with 1" type S screws 12" o.c.

OPPOSITE SIDE

C 1/2" Easi-Lite® drywall applied with 1" type S screws 12" o.c. All joints staggered.

D 3-1/2" CertainTeed® Fiber Glass Insulation or equivalent.

STC RATING

51

NOAL 17-1206

FIRE RATING

N/A

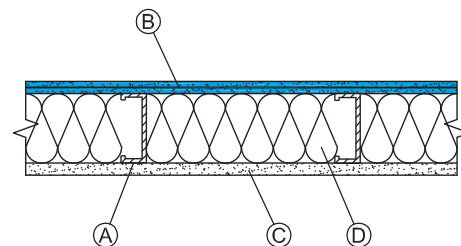

5/8" SILENTFX® QUICKCUT™ - STEEL STUD SYSTEMS

25 EQ (15 mil) 24" o.c. - 1 hr fire rating

A 3-5/8" 25 EQ (15 mil) steel studs 24" o.c.

ONE SIDE

B 5/8" SilentFX QuickCut Type X applied with 1" type S screws 8" o.c. and 12" o.c. top and bottom of wall.

OPPOSITE SIDE

C 5/8" CertainTeed® Type X applied with 1" type S screws 8" o.c. and 12" o.c. top and bottom of wall. All joints staggered.

D 3-1/2" CertainTeed® Fiber Glass Insulation or equivalent.

STC RATING

55

OL 18-0804

FIRE RATING

1 hr.

UL/cUL V450,

V486

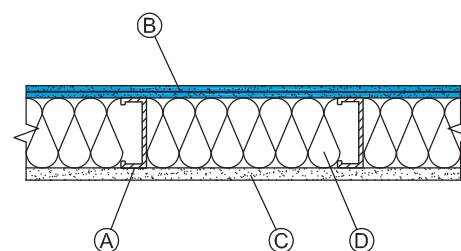

5/8" SILENTFX® QUICKCUT™ – STEEL STUD SYSTEMS

25 EQ (15 mil) 24" o.c. – 2 hr fire rating

A 3-5/8" 25 EQ (15 mil) steel studs 24" o.c.

ONE SIDE

B Face layer 5/8" SilentFX QuickCut Type X applied with 1-5/8" type S screws 12" o.c.

C Base layer 5/8" CertainTeed® Type X applied with 1" type S screws 12" o.c.

OPPOSITE SIDE

D Base layer 5/8" CertainTeed® Type X applied with 1" type S screws 12" o.c.

E Face layer 5/8" CertainTeed® Type X applied with 1-5/8" type S screws 12" o.c. All joints staggered.

F 3-1/2" CertainTeed® Fiber Glass Insulation or equivalent.

STC RATING

60

OL 17-0203

FIRE RATING

2 hr.

UL/cUL U411,

V450, V486

ULC W404

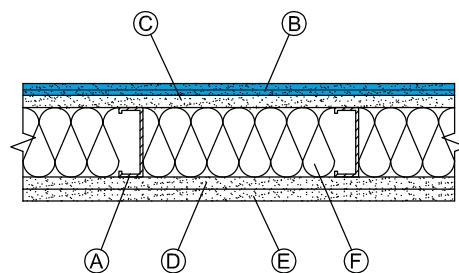

25 ga. (18 mil) 24" o.c. – 1 hr fire rating

A 3-5/8" 25 ga. (18 mil) steel studs 24" o.c.

ONE SIDE

B 5/8" SilentFX QuickCut Type X applied with 1" type S screws 8" o.c. perimeter and 12" o.c. field

OPPOSITE SIDE

C 5/8" CertainTeed® Type X applied with 1" type S screws 8" o.c. perimeter and 12" o.c. field. All joints staggered.

D 3-1/2" CertainTeed® Fiber Glass Insulation or equivalent.

STC RATING

55

OL 19-0719

FIRE RATING

1 hr.

UL/cUL U465

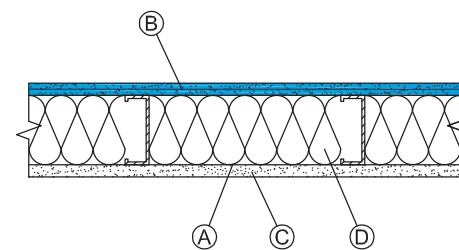

A 3-5/8" 25 ga. (18 mil) steel studs 24" o.c.

ONE SIDE

B Base layer 5/8" CertainTeed® Type X applied with 1" type S screws 16" o.c.

C Face layer 5/8" SilentFX QuickCut Type X applied with 1-5/8" type S screws 16" o.c.

OPPOSITE SIDE

D 5/8" CertainTeed® Type X applied with 1" type S screws 16" o.c. All joints staggered.

E 5/8" CertainTeed® Type X applied with 1-5/8" type S screws 16" o.c.

F 3-1/2" CertainTeed® Fiber Glass Insulation or equivalent.

STC RATING

58

OL 18-1239

FIRE RATING

1 hr.

UL/cUL U465,

V450, V486

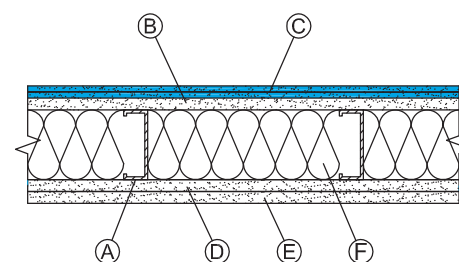

20 EQ (18 mil) 16" o.c. – 1 hr fire rating

A 3-5/8" 20 EQ (18 mil) steel studs 16" o.c.

ONE SIDE

B 5/8" SilentFX QuickCut Type X applied with 1" type S screws 8" o.c. perimeter and 12" o.c. field

OPPOSITE SIDE

C 5/8" CertainTeed® Type X applied with 1" type S screws 8" o.c. perimeter and 12" o.c. field

D 3-1/2" CertainTeed® Fiber Glass Insulation or equivalent

STC RATING

47

NOAL 21-0655

FIRE RATING

1 hr.

UL/cUL U465

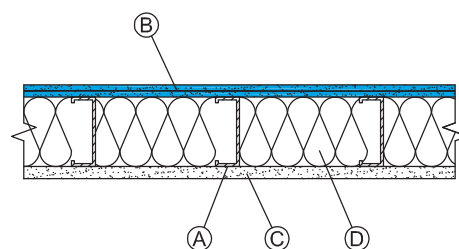

NOTE: SilentFX® QuickCut™ drywall panels can be used as either the base or face layer in a multi-layer system without affecting the STC rating. Equivalent fiber glass insulations may be substituted for CertainTeed Insulation products.

5/8" (15.9 mm) SILENTFX® QUICKCUT™ - STEEL STUD SYSTEMS

20 EQ (18 mil) 24" o.c. - 1 hr fire rating

- A** 3-5/8" 20 EQ (18 mil) steel studs 24" o.c.
ONE SIDE
B 5/8" SilentFX QuickCut Type X applied with 1" type S screws 8" o.c. perimeter and 12" o.c. field
OPPOSITE SIDE
C 5/8" CertainTeed® Type X applied with 1" type S screws 8" o.c. perimeter and 12" o.c. field
D 3-1/2" CertainTeed® Fiber Glass Insulation or equivalent

STC RATING
52
NOAL 21-0652

FIRE RATING
1 hr.
UL/cUL U465

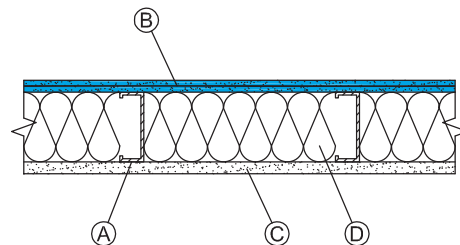

- A** 3-5/8" 20 EQ (18 mil) steel studs 24" o.c.
ONE SIDE
B 5/8" SilentFX QuickCut Type X applied with 1" type S screws 8" o.c. perimeter and 12" o.c. field
OPPOSITE SIDE
C 5/8" SilentFX QuickCut applied with 1" type S screws 8" o.c. perimeter and 12" o.c. field
D 3-1/2" CertainTeed® Fiber Glass Insulation or equivalent

STC RATING
55
NOAL 21-0653

FIRE RATING
1 hr.
UL/cUL U465

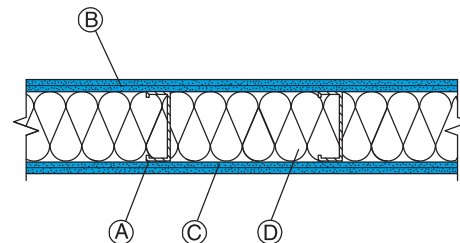

- A** 3-5/8" 20 EQ (18 mil) steel studs 24" o.c.
ONE SIDE
B 5/8" CertainTeed® Type X applied with 1" type S screws 8" o.c. perimeter and 12" o.c. field
OPPOSITE SIDE
C Resilient channel 24" o.c.
D 5/8" SilentFX QuickCut applied with 1" type S screws 8" o.c.
E 3-1/2" CertainTeed® Fiber Glass Insulation or equivalent

STC RATING
55
NOAL 21-0654

FIRE RATING
1 hr.
UL/cUL U465

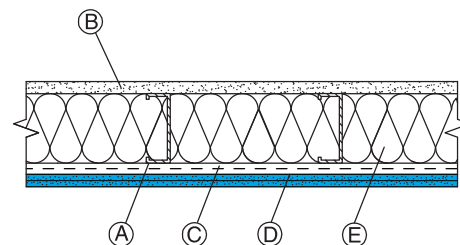

20 ga (33 mil) 16" o.c. - 1 hr fire rating

- A** 3-5/8" 20 ga. (33 mil) steel studs 16" o.c.
ONE SIDE
B 5/8" SilentFX QuickCut Type X applied with 1" type S-12 screws 12" o.c.
OPPOSITE SIDE
C 5/8" CertainTeed® Type X applied with 1" type S-12 screws 12" o.c. All joints staggered.
D 3-1/2" CertainTeed® Fiber Glass Insulation or equivalent.

STC RATING
51
OL 17-0302

FIRE RATING
1 hr.
UL/cUL U425

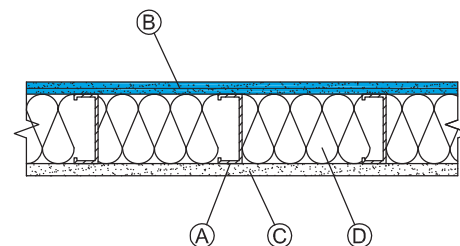

- A** 3-5/8" 20 ga. (33 mil) steel studs 16" o.c.
ONE SIDE
B 5/8" SilentFX QuickCut Type X applied with 1" type S-12 screws 12" o.c.
OPPOSITE SIDE
C 5/8" SilentFX QuickCut Type X applied with 1" type S-12 screws 12" o.c. All joints staggered.
D 3-1/2" CertainTeed® Fiber Glass Insulation or equivalent.

STC RATING
56
OL 17-0301

FIRE RATING
1 hr.
UL/cUL U425

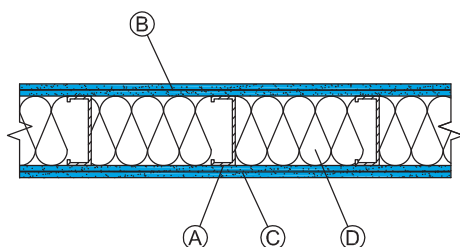

5/8" SILENTFX® QUICKCUT™ – STEEL STUD SYSTEMS

20 ga (33 mil) 16" o.c. – 1 hr fire rating

A 6" 20 ga. (33 mil) steel studs 16" o.c.

ONE SIDE

B 5/8" SilentFX QuickCut Type X applied with 1" type S-12 screws 12" o.c.

OPPOSITE SIDE

C 5/8" SilentFX QuickCut Type X applied with 1" type S-12 screws 12" o.c. All joints staggered.

D 6" CertainTeed® Fiber Glass Insulation or equivalent.

STC RATING

56

OL 17-0305

FIRE RATING

1 hr.

UL/cUL U425

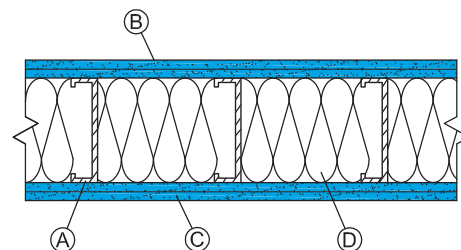

A 6" 20 ga. (33 mil) steel studs 16" o.c.

ONE SIDE

B 5/8" SilentFX QuickCut Type X with 1" type S-12 screws 12" o.c.

OPPOSITE SIDE

C Resilient channel 24" o.c

D 5/8" SilentFX QuickCut Type X applied with 1" type S screws 12" o.c. All joints staggered.

E 5" CertainTeed® Fiber Glass Insulation or equivalent.

STC RATING

60

OL 18-1226

FIRE RATING

1 hr.

UL/cUL U425

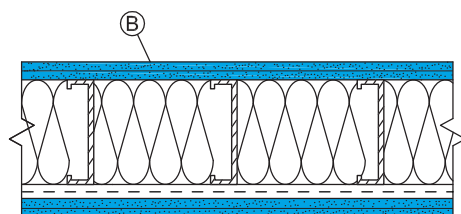

20 ga (33 mil) 16" o.c. – 2 hr fire rating

A 3-5/8" 20 ga. (33 mil) steel studs 16" o.c.

ONE SIDE

B Base layer 5/8" SilentFX QuickCut Type X applied with 1" type S-12 screws 12" o.c.

C Face layer 5/8" CertainTeed® Type X applied with 1-5/8" type S-12 screws 12" o.c.

OPPOSITE SIDE

D Base layer 5/8" CertainTeed® Type X applied with 1" type S-12 screws 12" o.c.

E Face layer 5/8" CertainTeed® Type X applied with 1-5/8" type S-12 screws 12" o.c. All joints staggered.

F 3-1/2" CertainTeed® Fiber Glass Insulation or equivalent.

STC RATING

58

OL 17-0303

FIRE RATING

2 hr.

UL/cUL U411,

U425

ULC W404

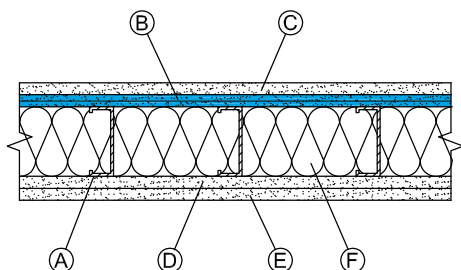

20 ga (33 mil) 24" o.c. – 1 hr fire rating

A 3-5/8" 20 ga. (33 mil) steel studs 24" o.c.

ONE SIDE

B 5/8" SilentFX QuickCut Type X applied with 1" type S-12 screws 12" o.c.

OPPOSITE SIDE

C 5/8" CertainTeed® Type X applied with 1" type S-12 screws 12" o.c. All joints staggered.

D 3-1/2" CertainTeed® Fiber Glass Insulation or equivalent.

STC RATING

56

OL 17-0229

FIRE RATING

1 hr.

UL/cUL U425

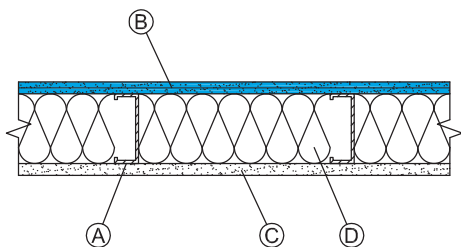

NOTE: SilentFX® QuickCut™ drywall panels can be used as either the base or face layer in a multi-layer system without affecting the STC rating. Equivalent fiber glass insulations may be substituted for CertainTeed Insulation products.

5/8" SILENTFX® QUICKCUT™ – STEEL STUD SYSTEMS

20 ga (33 mil) 24" o.c. – 1 hr fire rating

A 3-5/8" 20 ga. (33 mil) steel studs 24" o.c.

ONE SIDE

B 5/8" SilentFX QuickCut Type X applied with 1" type S-12 screws 12" o.c.

OPPOSITE SIDE

C 5/8" SilentFX QuickCut Type X applied with 1" type S-12 screws 12" o.c. All joints staggered.

D 3-1/2" CertainTeed® Fiber Glass Insulation or equivalent.

STC RATING

58

OL 17-0228

FIRE RATING

1 hr.

UL/cUL U425

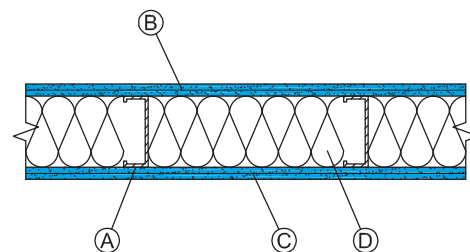

16 ga (54 mil) 16" o.c. – 1 hr fire rating

A 3-5/8" 16 ga. (54 mil) steel studs 16" o.c.

ONE SIDE

B 5/8" SilentFX QuickCut Type X applied with 1-1/4" type S-12 screws 12" o.c.

OPPOSITE SIDE

C 5/8" CertainTeed® Type X applied with 1-1/4" type S-12 screws 12" o.c. All joints staggered.

D 3-1/2" CertainTeed® Fiber Glass Insulation or equivalent.

STC RATING

48

OL 17-0324

FIRE RATING

1 hr.

UL/cUL U425

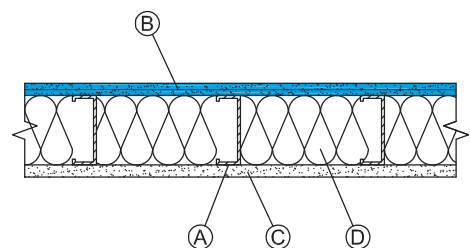

A 4" 16 ga. (54 mil) steel studs 16" o.c.

ONE SIDE

B 5/8" SilentFX QuickCut Type X with 1-1/4" type S-12 screws 12" o.c.

OPPOSITE SIDE

C 5/8" CertainTeed® Type X applied with 1-1/4" type S-12 screws 12" o.c. All joints staggered.

D 3-1/2" CertainTeed® Fiber Glass Insulation or equivalent.

STC RATING

50

OL 17-0231

FIRE RATING

1 hr.

UL/cUL U425

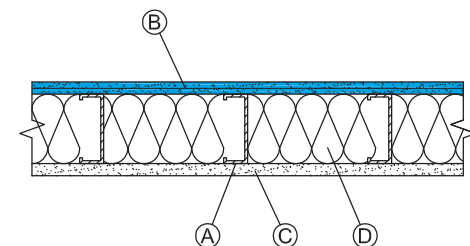

A 4" 16 ga. (54 mil) steel studs 16" o.c.

ONE SIDE

B 5/8" SilentFX QuickCut Type X applied with 1-1/4" type S-12 screws 12" o.c.

OPPOSITE SIDE

C 5/8" SilentFX QuickCut applied with 1-1/4" type S-12 screws 12" o.c. All joints staggered.

D 3-1/2" CertainTeed® Fiber Glass Insulation or equivalent.

STC RATING

52

OL 17-0224

FIRE RATING

1 hr.

UL/cUL U425

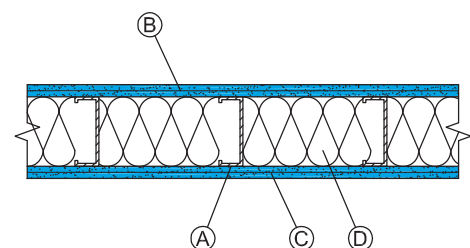

A 6" 16 ga. (54 mil) steel studs 16" o.c.

ONE SIDE

B 5/8" SilentFX QuickCut Type X applied with 1-1/4" type S-12 screws 12" o.c.

OPPOSITE SIDE

C 5/8" CertainTeed® Type X applied with 1-1/4" type S-12 screws 12" o.c. All joints staggered.

D 6" CertainTeed® Fiber Glass Insulation or equivalent.

STC RATING

52

OL 17-0321

FIRE RATING

1 hr.

UL/cUL U25

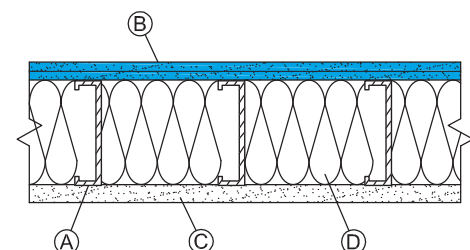

5/8" SILENTFX® QUICKCUT™ – STEEL STUD SYSTEMS

16 ga (54 mil) 16" o.c. – 1 hr fire rating

A 3-5/8" 16 ga. (54 mil) steel studs 16" o.c.

ONE SIDE

B Resilient channel 24" o.c.

C 5/8" SilentFX QuickCut Type X with 1" type S screws
12" o.c.

OPPOSITE SIDE

D 5/8" CertainTeed® Type X applied with 1-1/4" type S-12
screws 12" o.c. All joints staggered.

E 3-1/2" CertainTeed® Fiber Glass Insulation or equivalent.

STC RATING

53

OL 17-0325

FIRE RATING

1 hr.

UL/cUL U425

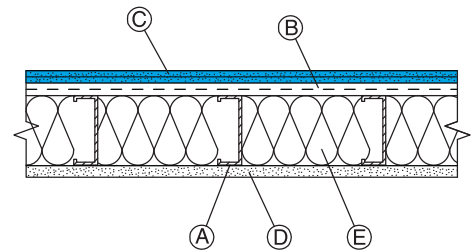

A 6" 16 ga. (53 mil) steel studs 16" o.c.

ONE SIDE

B 5/8" SilentFX QuickCut Type X applied with 1-1/4"
type S-12 screws 12" o.c.

OPPOSITE SIDE

C 5/8" SilentFX QuickCut Type X applied with 1-1/4"
type S-12 screws 12" o.c. All joints staggered.

D 6" CertainTeed® Fiber Glass Insulation or equivalent.

STC RATING

56

OL 17-0322

FIRE RATING

1 hr.

UL/cUL U425

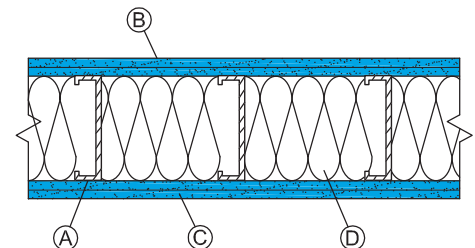

16 ga (54 mil) 16" o.c. – 2 hr fire rating

A 4" 16 ga (54 mil) steel studs 16" o.c.

ONE SIDE

B Base layer 5/8" SilentFX QuickCut Type X applied
with 1" type S-12 screws 16" o.c.

C Face layer 5/8" Extreme Abuse Type X applied with 1-5/8"
type S-12 screws 12" o.c. perimeter and 16" o.c. field

OPPOSITE SIDE

D Base layer 5/8" SilentFX QuickCut Type X applied with
1" type S-12 screws 16" o.c.

E Face layer 5/8" Extreme Abuse Type X applied with 1-5/8"
type S-12 screws 12" o.c. perimeter and 16" o.c. field

F 3-1/2" CertainTeed® Fiber Glass Insulation or equivalent

STC RATING

51

NOAL 18-0805

FIRE RATING

2 hr.

UL/cUL U411

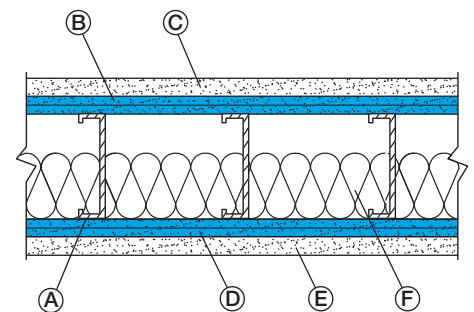

16 ga (54 mil) 24" o.c. – 1 hr fire rating

A 6" 16 ga. (54 mil) steel studs 24" o.c.

ONE SIDE

B 5/8" SilentFX QuickCut Type X applied with 1" type S-12
screws 12" o.c.

OPPOSITE SIDE

C Resilient channel 24" o.c.

D 5/8" SilentFX QuickCut Type X applied with 1" type S
screws 12" o.c.

E 6" CertainTeed® Fiber Glass Insulation or equivalent

STC RATING

60

NOAL 18-0323

FIRE RATING

1 hr.

UL/cUL U425

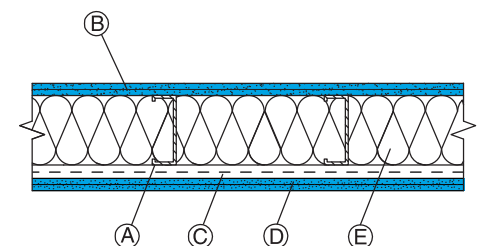

NOTE: SilentFX® QuickCut™ drywall panels can be used as either the base or face layer in a multi-layer system without affecting the STC rating. Equivalent fiber glass insulations may be substituted for CertainTeed Insulation products.

5/8" SILENTFX® QUICKCUT™ - STEEL STUD SYSTEMS

14 ga (68 mil) 16" o.c. - 1 hr fire rating

A 3-5/8" 14 ga. (68 mil) steel studs 16" o.c.

ONE SIDE

B 5/8" SilentFX QuickCut Type X applied with 1-1/4" type S-12 screws 12" o.c.

OPPOSITE SIDE

- C Base layer 5/8" CertainTeed® Type X applied with 1" type S-12 screws 12" o.c. All joints staggered.
 D Face layer 5/8" CertainTeed® Type X applied with 1-5/8" type S-12 screws 12"
 E 3-1/2" CertainTeed® Fiber Glass Insulation or equivalent.

STC RATING

44
 NOAL 18-0322

FIRE RATING

1 hr.
 UL/cUL U425

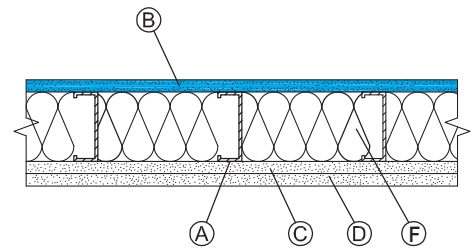

5/8" SILENTFX® QUICKCUT™ - STEEL STUD CHASE WALLS

25 EQ (15 mil) 24" o.c. - 1 hr fire rating

A Double row 3-5/8" 25 EQ (15 mil) steel studs 24" o.c., in separate tracks with a 1" gap.

ONE SIDE

B 5/8" SilentFX QuickCut Type X applied with 1" type S screws 8" o.c.

OPPOSITE SIDE

- C 5/8" CertainTeed® Type X applied with 1" type S screws 8" o.c. All joints staggered.
 D 3-1/2" CertainTeed® Fiber Glass Insulation or equivalent, both rows.

STC RATING

60
 NOAL 17-1205

FIRE RATING

1 hr.
 UL/cUL U420

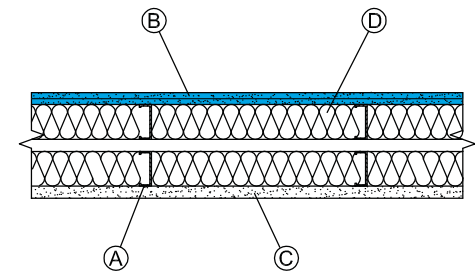

25 ga. (18 mil) 24" o.c. - 1 hr fire rating

A Double row 2-1/2" 25 ga. (18 mil) steel studs 24" o.c., in separate tracks with a 1" gap.

ONE SIDE

B 5/8" SilentFX QuickCut Type X applied with 1" type S screws 8" o.c. perimeter and 12" o.c. field

OPPOSITE SIDE

- C 5/8" CertainTeed® Type X applied with 1" type S screws 8" o.c. perimeter and 12" o.c. field. All joints staggered.
 D 2-1/2" CertainTeed® Fiber Glass Insulation or equivalent, both rows.

STC RATING

61
 OL 18-1003

FIRE RATING

1 hr.
 UL/cUL U420

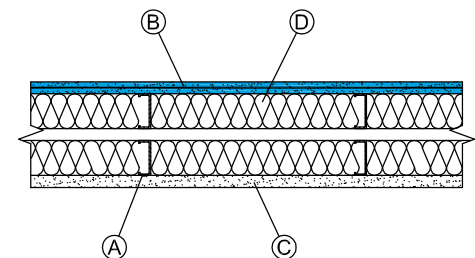

16 ga (54 mil) 24" o.c. - 1 hr fire rating

A Double row 3-5/8" 16 ga. (54 mil) steel studs 24" o.c., in separate tracks with a 1" gap

ONE SIDE

B 5/8" SilentFX QuickCut Type X applied with 1-1/4" type S-12 screws 8" o.c. perimeter and 12" o.c. field

OPPOSITE SIDE

- C 5/8" SilentFX QuickCut Type X applied with 1-1/4" type S-12 screws 8" o.c. perimeter and 12" o.c. field
 D 3-1/2" CertainTeed® Fiber Glass Insulation or equivalent, both rows

STC RATING

64
 NOAL 21-0454

FIRE RATING

1 hr.
 UL/cUL U420

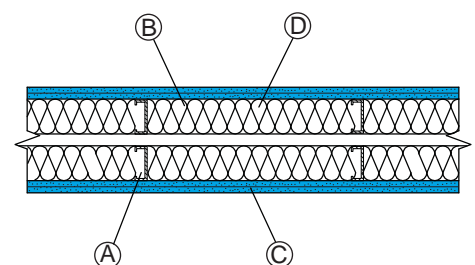

SOUND RATING FLOOR-CEILING ASSEMBLY DESCRIPTION

BASE ASSEMBLY

ONE SIDE

- A** Subflooring Nom. 19/32" T&G plywood perpendicular to joists with end joints staggered and secured to joists with construction adhesive and 6D ring shank nails or staples 12" o.c.
- B** Wood I-joists 9-1/2" deep wood I-joists spaced 24" o.c.
- C** Insulation 9-1/2" Optima® Loose Fill Insulation

OPPOSITE SIDE

- D** Resilient channels installed perpendicular to I-joists at 12" o.c.
- E** Base layer 5/8" SilentFX QuickCut Type X applied perpendicular to resilient channel with 1" type S screws 8" o.c.
- F** Face layer 1/2" CertainTeed® Type C applied perpendicular to the resilient channel with 1-5/8" type S screws 8" o.c.

STC RATING

54 (NGC 5017060)

IIC RATING

46 (NGC 5017091)

FIRE RATING

1 hr.

UL/cUL M535

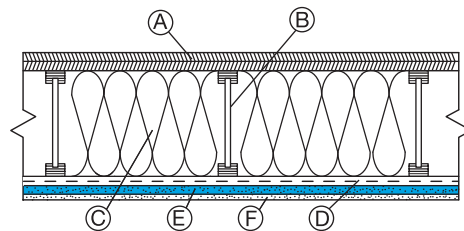

SOUND RATING FLOOR-CEILING ASSEMBLY DESCRIPTION

Base Assembly + finished floor of 3/4" Gypsum Concrete floor topping over sound mat with Carpet and Pad

STC
(TEST NO.)

60 (NGC 5017069)

IIC
(TEST NO.)

78 (NGC 5017110)

Base Assembly + finished floor of 3/4" Gypsum Concrete floor topping over sound mat with 3/16" Luxury Vinyl Tile (LVT)

60 (NGC 5017070)

57 (NGC 5017111)

Base Assembly + finished floor of 3/4" Gypsum Concrete floor topping over sound mat with 3/16" Luxury Vinyl Tile (LVT) over underlayment

62 (NGC 5017071)

58 (NGC 5017112)

Base Assembly + finished floor of 3/4" Gypsum Concrete floor topping over sound mat with 3/8" Luxury Vinyl Tile (LVT) over Engineered Hardwood

60 (NGC 5017072)

58 (NGC 5017113)

NOTE: SilentFX® QuickCut™ drywall panels can be used as either the base or face layer in a multi-layer system without affecting the STC rating. Equivalent fiber glass insulations may be substituted for CertainTeed Insulation products.

CertainTeed builds better environments

CertainTeed has the unique advantage of offering some of the most comprehensive interior building solutions in the industry.

Our drywall systems, along with our full building materials portfolio, are created with the goal of improving occupant health and well-being in all the places where we live, learn, work, heal, and play. With CertainTeed, you'll be able to make any space a better home, quickly and efficiently.



SilentFX® QuickCut™ noise-reducing drywall panel significantly improves sound attenuation and is ideal for systems requiring high STC performance. M2Tech® technology provides added moisture and mold resistance.



M2Tech® Moisture and Mold Resistant drywall panel features a unique technology that combines moisture and mold resistance and is specially engineered to provide enhanced protection against mold growth.



Extreme Abuse and Extreme Impact provide increased protection and durability for areas subjected to repeat wear and tear. Available with M2Tech® technology for added mold resistance.



GlasRoc® Tile Backer, part of the GlasRoc® family, is the superior tile substrate for walls, ceilings, countertops and other moisture prone areas.



Easi-Lite® Lightweight drywall panel is up to 30% lighter than standard drywall panels. Easi-Lite®, as well as other CertainTeed paper faced drywall panels, are made with recycled paper.



The GlasRoc® family of products combines re-inforcing Glass mats, fully embedded into a water-resistant gypsum core, positioned beneath a paperless polymer-modified gypsum surface, and a protective acrylic coating on the exterior face. Available in exterior sheathing, shaftliner and interior drywall panel.



Most CertainTeed panel products are available with a 5/8" (15.7 mm) Type X, fire-resistant, gypsum core.



CertainTeed provides innovative building products and systems for commercial, institutional and residential designs. With over 80 years of experience manufacturing and marketing in North America, CertainTeed Gypsum is committed to focusing on quality, service, and safety to provide a superior experience to its customers.

TEST STANDARDS

Fire resistance and sound tests are conducted in accordance with ASTM E119 (UL 263, CAN/ULC-S101) and ASTM E90, respectively, and no warranty is made other than conformance to the standard under which the assembly was tested. Minor discrepancies may exist in the values of ratings, attributable to changes in materials and standards, as well as differences between testing facilities.

Assemblies are listed as “combustible” (wood framing) and “noncombustible” (concrete and/or steel construction).

COMBUSTIBLE ASSEMBLIES

These include all wood stud walls, wood joist or truss ceilings and floors consisting of tongue-and-groove, plywood, or OSB sub-flooring and finish flooring or a poured gypsum floor underlayment over wood structural panel sub-flooring. Floor assembly may be used over the wood joists with ceilings as detailed in GA and UL/cUL/ULC references.

NONCOMBUSTIBLE ASSEMBLIES

These include steel studs, bar joist ceilings with poured concrete floors over metal lath or steel. Also included are steel beams and steel columns. Ceilings for all 1-hour, 1 1/2-hour, and 2-hour noncombustible floor and

ceiling assemblies with 2” or 2 1/2” concrete floor or metal lath over steel bar joists, unless otherwise specified, may be directly attached or suspended as detailed in GA and UL/cUL/ULC references.

FIRE RESISTANCE

CertainTeed® Type X and Type C, M2Tech® Type X, SilentFX® QuickCut™ Type X, GlasRoc® Tile Backer Type X, GlasRoc® Shaftliner Type X, GlasRoc® Interior Type X and GlasRoc® Sheathing Type X products are Classified by Underwriters Laboratories Inc. and Listed by Underwriters Laboratories of Canada and carries the UL/cUL/ULC Label for 1-, 2-, 3- and 4-hour Fire Resistance in various designs. Underwriters Laboratories Inc. tests have proven that joint finishing is not required for the rating in certain assemblies using Type X and Type C



products. For fire resistance ratings, refer to the Gypsum Association Fire Resistance Design Manual GA-600, and the UL, cUL and ULC Fire Resistance Directories.

SURFACE BURNING CHARACTERISTICS

CertainTeed® Gypsum Panels have Flame Spread ratings of 0 to 15 and Smoke Developed ratings of 0 to 5, and GlasRoc® products have Flame Spread Ratings of 0 and Smoke Developed Ratings of 0 in accordance with ASTM E84 (UL 723, CAN/ULC-S102).

SOUND CHARACTERISTICS

The degree to which assemblies block the passage of sound is measured by Sound Transmission Class (STC) per ASTM E90 and E413, which is a single figure rating derived from the sound transmission loss values over a range of sound frequencies. All sound-rated

assemblies require acoustical sealant at assembly perimeters and penetrations, and other locations where sound leaks may develop. For sound characteristics, refer to the Gypsum Association Fire Resistance Design Manual GA-600.

STORAGE

Gypsum panels must be stored in an area that protects it from adverse weather conditions, condensation and other forms of moisture and direct sunlight. Panels should be neatly stacked flat with care taken to prevent sagging or damage to edges, ends, and surfaces. Storing panels lengthwise leaning against the framing is not recommended. Panels should be carried, not dragged, to place of installation to prevent damaging finished edges. Refer to “Handling and Storage of Gypsum Panel Products” GA-801.

MORE INFORMATION

Consult the Gypsum Association publication “Recommended Specifications for the Application and Finishing of Gypsum Panel,” GA-216, for detailed application and finishing procedures. For full details of fire and sound ratings, consult test references listed for system assemblies.

Characteristics, properties or performance of materials or systems manufactured by CertainTeed herein described are derived from data obtained under controlled test conditions. CertainTeed makes no warranties, express or implied, as to their characteristics, properties or performance under any variations from such conditions in actual construction. CertainTeed assumes no responsibility for the effects of structural movement. TMCertainTeed is a trademark CertainTeed Corporation. All other trademarks are the property of its affiliates and related companies. NOTICE: The information in this document is subject to change without notice. CertainTeed assumes no responsibility for any errors that may inadvertently appear in this document.

Reducing noise is good for business.
 Visit CertainTeed.com/SilentFX or call 800-233-8990



learn more at
certainteed.com/silentfx

USGBC® and the related logo are trademarks owned by the U.S. Green Building Council® and are used with permission.



The Health Product Declaration® logo is a trademark or service mark of Health Product Declaration Collaborative, Inc., in the United States and in other countries and is being used herein under license.



CertainTeed

CEILINGS • DECKING • FENCE • GYPSUM • INSULATION • RAILING • ROOFING • SIDING • TRIM
 20 Moores Road, Malvern, PA 19355 800-233-8990 certainteed.com